

CHF Series Universal Inverter Operation Manual



- Thank you very much for your buying CHF series universal inverter.
- Before use, please read this manual thoroughly to ensure proper usage. Keep this manual at an easily accessible place so that can refer anytime as necessary.

Safety Precautions

Please read this operation manual carefully before installation, operation, maintenance or inspection.

In this manual, the safety precautions were sorted to "WARNING" or "CAUTION".



WARNING

Indicates a potentially dangerous situation which, if can not avoid will result in death or serious injury.



CAUTION

Indicates a potentially dangerous situation which, if can not avoid will cause minor or moderate injury and damage the device. This

Symbol is also used for warning any un-safety operation.

In some cases, even the contents of "CAUTION" still can cause serious accident. Please follow these important precautions in any situation.

★ **NOTE** indicate the necessary operation to ensure the device run properly.

Warning Marks are placed on the front cover of the inverter.

Please follow these indications when using the inverter.

WARNING	
<ul style="list-style-type: none">● May cause injury or electric shock.● Please follow the instructions in the manual before installation or operation.● Disconnect all power line before opening front cover of unit. Wait at least 1 minute until DC Bus capacitors discharge.● Use proper grounding techniques.● Never connect AC power with UVW terminals	

TABLE OF CONTENTS

TABLE OF CONTENTS	II
LIST OF FIGURES	IV
1. INTRODUCTION	1
1.1 Technology Features	1
1.2 Description of Name Plate	2
1.3 Selection Guide	2
1.4 Parts Description	5
1.5 External Dimension	6
2. INSPECTION	8
3. INSTALLATION	9
3.1 Environmental Requirement	10
3.2 Installation Space	11
3.3 Dimensions of External Keypad	12
3.4 Disassembly	12
4. WIRING	14
4.1 Connection of Peripheral Devices	15
4.2 Terminal Configuration	16
4.2.1 Main Circuit Terminals	16
4.2.2 Control Circuit Terminals	17
4.3 Typical Wiring Diagram	18
4.4 Specifications of Breaker, Cable, Contactor and Reactor	19
4.4.1 Specifications of breaker, cable and contactor	19
4.4.2 Specifications of AC input/output reactor and DC reactor	20
4.4.3 Specifications of braking resistor	21
4.5 Wiring Main Circuits	23
4.5.1 Wiring at input side of main circuit	23
4.5.2 Wiring at inverter side of main circuit	23
4.5.3 Wiring at motor side of main circuit	24
4.5.4 Wiring of regenerative unit	24
4.5.5 Wiring of Common DC bus	25
4.5.6 Ground Wiring (PE)	26
4.6 Wiring Control Circuit	26
4.6.1 Precautions	26
4.6.2 Control circuit terminals	26
4.6.3 Jumper on control board	27
4.7 Installation Guideline to EMC Compliance	28
4.7.1 General knowledge of EMC	28
4.7.2 EMC features of inverter	28
4.7.3 EMC Installation Guideline	29
5. OPERATION	31
5.1 Keypad Description	31
5.1.1 Keypad schematic diagram	31
5.1.2 Function key description	31
5.1.3 Indicator light description	32

5.2 Operation Process	33
5.2.1 Parameter setting	33
5.2.2 Fault reset	34
5.2.3 Motor parameters autotuning	34
5.2.4 Password setting	34
5.2.5 Shortcut menu setting	34
5.3 Running State	35
5.3.1 Power-on initialization	35
5.3.2 Stand-by	35
5.3.3 Motor parameters autotuning	35
5.3.4 Operation	35
5.3.5 Fault	35
5.4 Shortcut Menu.....	36
5.4.1 Shortcut menu operation.....	36
5.4.2 Quick debugging mode	37
6. DETAILED FUNCTION DESCRIPTION.....	39
6.1 P0 Group--Basic Function	39
6.2 P1 Group --Start and Stop Control.....	45
6.3 P2 Group--Motor Parameters.....	49
6.4 P3 Group—Frequency Setting.....	50
6.5 P4 Group—V/F Control.....	54
6.6 P5 Group--Input Terminals.....	56
6.7 P6 Group--Output Terminals.....	64
6.8 P7 Group—Display Interface	67
6.9 P8 Group--Enhanced Function.....	72
6.10 P9 Group--PID Control	78
6.11 PA Group--Simple PLC and Multi-steps Speed Control.....	82
6.12 PB Group-- Protection Function	88
6.13 PC Group--Serial Communication	91
6.14 PD Group--Supplementary Function	93
6.15 PE Group—Factory Setting	94
7. TROUBLE SHOOTING	95
7.1 Fault and Trouble shooting	95
7.2 Common Faults and Solutions.....	97
8. MAINTENANCE.....	98
8.1 Daily Maintenance	98
8.2 Periodic Maintenance	99
8.3 Replacement of wearing parts	99
9. LIST OF FUNCTION PARAMETERS.....	101
10. COMMUNICATION PROTOCOL.....	119

LIST OF FIGURES

Figure 1.1	Nameplate of inverter.	2
Figure 1.2	Parts of inverter (15kw and below).	5
Figure 1.3	Parts of inverter (18.5kw and above).	6
Figure 1.4	Dimensions (15kW and below).	6
Figure 1.5	Dimensions (18.5 ~110kW).	6
Figure 1.6	Dimensions (132~315kW).	6
Figure 1.7	Dimensions (350~630kW).	7
Figure 3.1	Relationship between output current and altitude.	10
Figure 3.2	Safety space.	11
Figure 3.3	Installation of multiple inverters.	11
Figure 3.4	Dimension of small keypad.	12
Figure 3.5	Dimension of big keypad.	12
Figure 3.6	Disassembly of plastic cover.	12
Figure 3.7	Disassembly of metal plate cover.	13
Figure 3.8	Open inverter cabinet.	13
Figure 4.1	Connection of peripheral devices.	15
Figure 4.2	Main circuit terminals (1.5~2.2kW).	16
Figure 4.3	Main circuit terminals (4~5.5kW).	16
Figure 4.4	Main circuit terminals (7.5~15kW).	16
Figure 4.5	Main circuit terminals (18.5~110kW).	16
Figure 4.6	Main circuit terminals (132~315kW).	16
Figure 4.7	Main circuit terminals (350~630kW).	16
Figure 4.8	Control circuit terminals (1.5~2.2kW).	17
Figure 4.9	Control circuit terminals (4kW and above).	17
Figure 4.10	Wiring diagram.	18
Figure 4.11	Wiring at input side.	23
Figure 4.12	Wiring at motor side.	24
Figure 4.13	Wiring of regenerative unit.	25
Figure 4.14	Wiring of common DC bus.	25
Figure 5.1	Keypad schematic diagram.	31
Figure 5.2	Flow chart of parameter setting.	33
Figure 5.3	Shortcut menu operation.	36
Figure 6.1	Acceleration and deceleration time.	41
Figure 6.2	Multiple V/F curve diagram.	42
Figure 6.3	Torque boost diagram.	42
Figure 6.4	Effect of carrier frequency.	43
Figure 6.5	Starting diagram.	45

Figure 6.6	DC braking diagram.....	47
Figure 6.7	FWD/REV dead time diagram.	47
Figure 6.8	Reference frequency diagram.	52
Figure 6.9	Skip frequency diagram.....	54
Figure 6.10	V/F curve setting diagram.....	56
Figure 6.11	2-wire control mode 1.....	60
Figure 6.12	2-wire control mode 2.....	60
Figure 6.13	3-wire control mode 1.....	61
Figure 6.14	3-wire control mode 2.....	61
Figure 6.15	Relationship between AI and corresponding setting.	62
Figure 6.16	Relationship between AO and corresponding setting.	66
Figure 6.17	Relationship between HDO and corresponding setting.....	67
Figure 6.18	Traverse operation diagram.	73
Figure 6.19	Timing chart for preset and specified count reached.	75
Figure 6.20	FDT level and lag diagram.	75
Figure 6.21	Frequency arriving detection diagram.	76
Figure 6.22	Droop control diagram.....	76
Figure 6.23	Simple water-supply control function diagram.....	77
Figure 6.24	PID control diagram.....	79
Figure 6.25	Reducing overshooting diagram.....	80
Figure 6.26	Rapidly stabilizing diagram.....	81
Figure 6.27	Reducing long-cycle oscillation diagram.	81
Figure 6.28	Reducing short-cycle oscillation diagram.	81
Figure 6.29	Relationship between bias limit and output frequency.	82
Figure 6.30	Simple PLC operation diagram.....	83
Figure 6.31	Multi-steps speed operation diagram.	85
Figure 6.32	Simple PLC continue from paused step.	87
Figure 6.33	Motor overload protection curve.....	88
Figure 6.34	Over-voltage stall function.	89
Figure 6.35	Current limiting protection function.....	90
Figure 6.36	Meaning of PC.06.....	93

1. INTRODUCTION

1.1 Technology Features

• Input & Output

- ◆ Input Voltage Range: 380/220V±15%
- ◆ Input Frequency Range: 47~63Hz
- ◆ Output Voltage Range: 0~rated input voltage
- ◆ Output Frequency Range: 0~400Hz

• I/O Features

- ◆ Programmable Digital Input: Provide 4 terminals which can accept ON-OFF inputs, and 1 terminal which can accept high speed pulse input.
- ◆ Programmable Analog Input: AI1 can accept input of 0 ~10V, AI2 can accept input of 0~10V or 0~20mA.
- ◆ Programmable Open Collector Output: Provide 1 output terminal (open collector output or high speed pulse output)
- ◆ Relay Output: Provide 2 output terminals (1 for 2.2kW and below)
- ◆ Analog Output: Provide 1 output terminal, whose output scope can be 0/4~20 mA or 0~10 V, as chosen.

• Main Control Function

- ◆ Control Mode: V/F control.
- ◆ Overload Capacity: 60s with 150% of rated current, 10s with 180% of rated current.
- ◆ Speed Adjusting Range: 1:100.
- ◆ Carrier Frequency: 0.5kHz ~15.0kHz.
- ◆ Frequency reference source: keypad, analog input, HDI, serial communication, multi-step speed, simple PLC and PID. The combination of multi- modes and the switch between different modes can be realized.
- ◆ PID Control Function
- ◆ Simple PLC, Multi-Steps Speed Control Function: 16 steps speed can be set.
- ◆ Traverse Control Function
- ◆ Length and Time Control Function
- ◆ None-Stop when instantaneous power off.
- ◆ Speed Trace Function: Smoothly start the running motor.
- ◆ QUICK/JOG Key: User defined shortcut key can be realized.
- ◆ Automatic Voltage Regulation Function (AVR):
Automatically keep the output voltage stable when input voltage fluctuating
- ◆ Up to 23 fault protections:
Protect from over current, over voltage, under voltage, over temperature, phase failure, over load etc.

1.2 Description of Name Plate

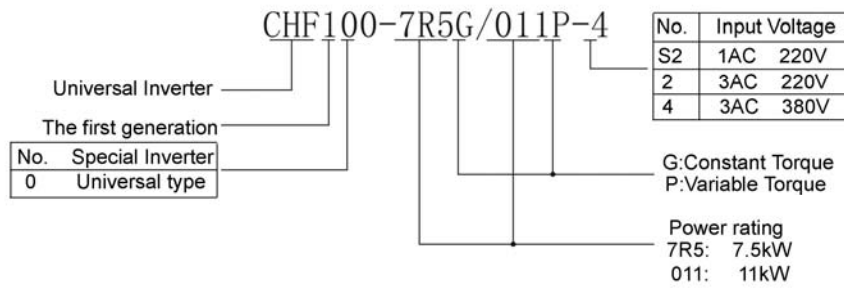

Figure 1.1 Nameplate of inverter.

1.3 Selection Guide

Model No.	Rated output Power (kW)	Rated input current (A)	Rated output current (A)	Size
1AC 220V ±15%				
CHF100-1R5G-S2	1.5	14.2	7.0	B
CHF100-2R2G-S2	2.2	23.0	10	B
3AC 220V ±15%				
CHF100-0R7G-2	0.75	5.0	4.5	B
CHF100-1R5G-2	1.5	7.7	7	B
CHF100-2R2G-2	2.2	11.0	10	B
CHF100-004G-2	4.0	17.0	16	C
CHF100-5R5G-2	5.5	21.0	20	C
CHF100-7R5G-2	7.5	31.0	30	D
CHF100-011G-2	11.0	43.0	42	E
CHF100-015G-2	15.0	56.0	55	E
CHF100-018G-2	18.5	71.0	70	E
CHF100-022G-2	22.0	81.0	80	F
CHF100-030G-2	30.0	112.0	110	F
CHF100-037G-2	37.0	132.0	130	F
CHF100-045G-2	45.0	163.0	160	G
3AC 380V ±15%				
CHF100-0R7G-4	0.75	3.4	2.5	B

CHF100-1R5G-4	1.5	5.0	3.7	B
CHF100-2R2G-4	2.2	5.8	5	B
CHF100-004G/5R5P-4	4.0/5.5	10/15	9/13	C
CHF100-5R5G/7R5P-4	5.5/7.5	15/20	13/17	C
CHF100-7R5G/011P-4	7.5/11	20/26	17/25	D
CHF100-011G/015P-4	11/15	26/35	25/32	D
CHF100-015G/018P-4	15/ 18.5	35/38	32/37	D
CHF100-018G/022P-4	18.5/ 22	38/46	37/45	E
CHF100-022G/030P-4	22/30	46/62	45/60	E
CHF100-030G/037P-4	30/37	62/76	60/75	E
CHF100-037G/045P-4	37/45	76/90	75/90	F
CHF100-045G/055P-4	45/55	90/105	90/110	F
CHF100-055G/075P-4	55/75	105/ 140	110/ 150	F
CHF100-075G/090P-4	75/90	140/ 160	150/ 176	G
CHF100-090G/110P-4	90/110	160/ 210	176/ 210	G
CHF100-110G/132P-4	110/132	210/ 240	210/ 250	G
CHF100-132G/160P-4	132/160	240/ 290	250/ 300	H
CHF100-160G/185P-4	160/185	290/ 330	300/ 340	H
CHF100-185G/200P-4	185/200	330/ 370	340/ 380	H
CHF100-200G/220P-4	200/220	370/ 410	380/ 415	I
CHF100-220G/250P-4	220/250	410/ 460	415/ 470	I
CHF100-250G/280P-4	250/280	460/ 500	470/ 520	I
CHF100-280G/315P-4	280/315	500/ 580	520/ 600	I
CHF100-315G/350P-4	315/350	580/ 620	600/ 640	I
CHF100-350G-4	350	620	640	2*H
CHF100-400G-4	400	670	690	2*I
CHF100-500G-4	500	835	860	2*I
CHF100-560G-4	560	920	950	2*I
CHF100-630G-4	630	1050	1100	2*I
CHF100-710G-4	710	1250	1300	3*I
CHF100-800G-4	800	1450	1520	3*I
3AC 690V ±15%				

Introduction

CHF100-022G-6	22	35	28	E
CHF100-030G-6	30	40	35	E
CHF100-037G-6	37	47	45	F
CHF100-045G-6	45	52	52	F
CHF100-055G-6	55	65	63	F
CHF100-075G-6	75	85	86	F
CHF100-090G-6	90	95	98	G
CHF100-110G-6	110	118	121	G
CHF100-132G-6	132	145	150	G
CHF100-160G-6	160	165	175	H
CHF100-185G-6	185	190	198	H
CHF100-200G-6	200	210	218	H
CHF100-220G-6	220	230	240	I
CHF100-250G-6	250	255	270	I
CHF100-280G-6	280	285	300	I
CHF100-315G-6	315	334	350	I
CHF100-350G-6	350	360	380	I
CHF100-400G-6	400	411	430	I
CHF100-500G-6	500	518	540	2*I
CHF100-560G-6	560	578	600	2*I
CHF100-630G-6	630	655	680	2*I

1.4 Parts Description

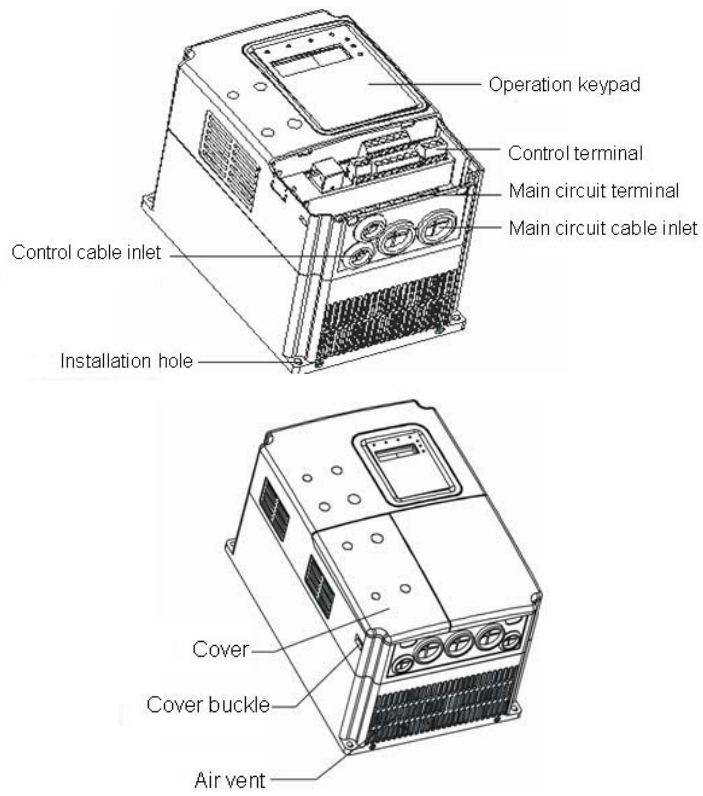
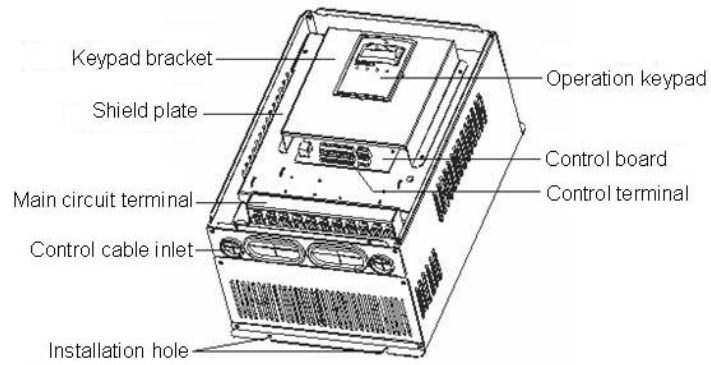

Figure 1.2 Parts of inverter (15kw and below).



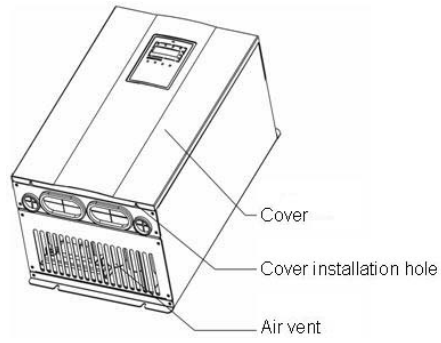

Figure 1.3 Parts of inverter (18.5kw and above).

1.5 External Dimension

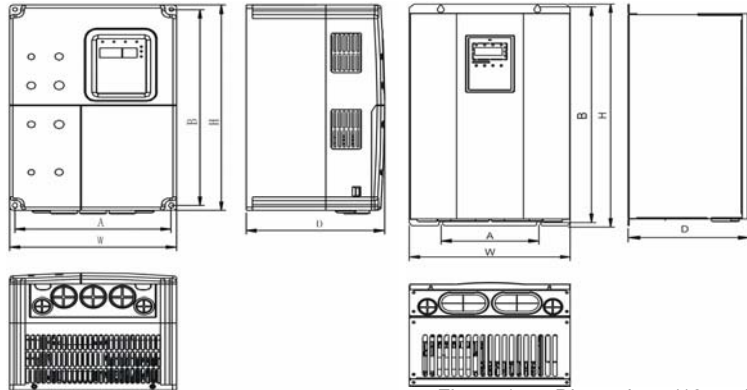

Figure 1.4 Dimensions (15kW and below).

Figure 1.5 Dimensions (18.5~110kW).

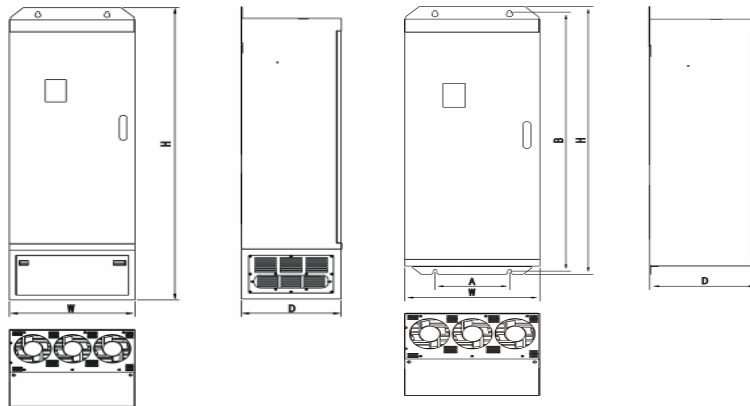

Figure 1.6 Dimensions (132~315kW).

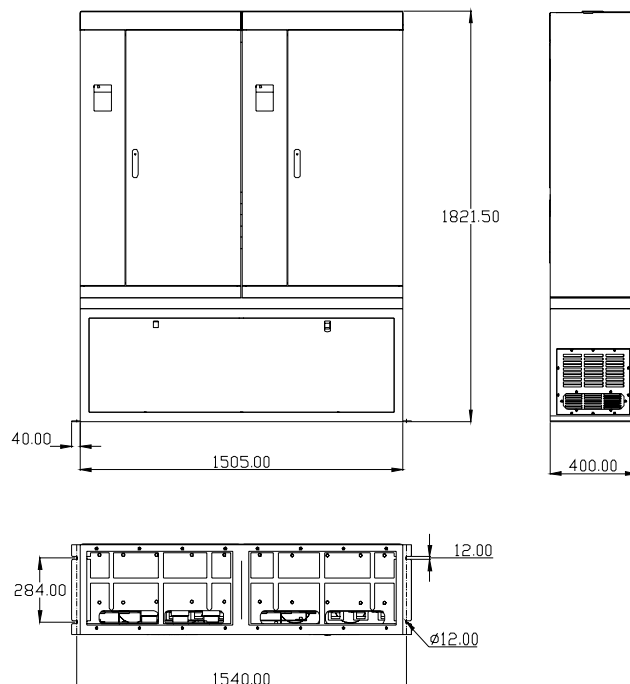

Figure 1.7 Dimensions (350~630kW).

Power (kW)	Size	A (mm)	B (mm)	H (mm)	W (mm)	D (mm)	Installation Hole (mm)
		Installation Dimension		External Dimension			
0.75~2.2	B	110.4	170.2	180	120	140	5
4~5.5	C	147.5	237.5	250	160	175	5
7.5~15	D	206	305.5	320	220	180	6.0
18.5~30	E	176	454.5	467	290	215	6.5
37~55	F	230	564.5	577	375	270	7.0
75~110	G	320	738.5	755	460	330	9.0
132~185	H(without base)	270	1233	1275	490	391	13.0
	H(with base)	—	—	1490	490	391	—
200~315	I(without base)	500	1324	1358	750	402	12.5
	I(with base)	—	—	1670	750	402	—
350~630	J(with base)	See Figure 1.7					

2. INSPECTION



CAUTION

- **Don't install or use any inverter that is damaged or have fault part, otherwise may cause injury.**

Check the following items when unpacking the inverter,

1. Inspect the entire exterior of the Inverter to ensure there are no scratches or other damage caused by the transportation.
2. Ensure there is operation manual and warranty card in the packing box.
3. Inspect the nameplate and ensure it is what you ordered.
4. Ensure the optional parts are what you need if have ordered any optional parts.

Please contact the local agent if there is any damage in the inverter or optional parts.

3. INSTALLATION



WARNING

- The person without passing the training manipulate the device or any rule in the “Warning” being violated, will cause severe injury or property loss. Only the person, who has passed the training on the design, installation, commissioning and operation of the device and gotten the certification, is permitted to operate this equipment.
- Input power cable must be connected tightly, and the equipment must be grounded securely.
- Even if the inverter is not running, the following terminals still have dangerous voltage:
 - Power Terminals: R, S, T
 - Motor Connection Terminals: U, V, W.
- When power off, should not install the inverter until 5 minutes after, which will ensure the device discharge completely.
- The section area of grounding conductor must be no less than that of power supply cable.



CAUTION

- When moving the inverter please lift by its base and don't lift by the panel. Otherwise may cause the main unit fall off which may result in personal injury.
- Install the inverter on the fireproofing material (such as metal) to prevent fire.
- When need install two or more inverters in one cabinet, cooling fan should be provided to make sure that the air temperature is lower than 45°C. Otherwise it could cause fire or damage the device.

3.1 Environmental Requirement

3.1.1 Temperature

Environment temperature range: $-10^{\circ}\text{C} \sim +40^{\circ}\text{C}$. Inverter will be derated if ambient temperature exceeds 40°C .

3.1.2 Humidity

Less than 95% RH, without dewfall.

3.1.3 Altitude

Inverter can output the rated power when installed with altitude of lower than 1000m. It will be derated when the altitude is higher than 1000m. For details, please refer to the following figure:

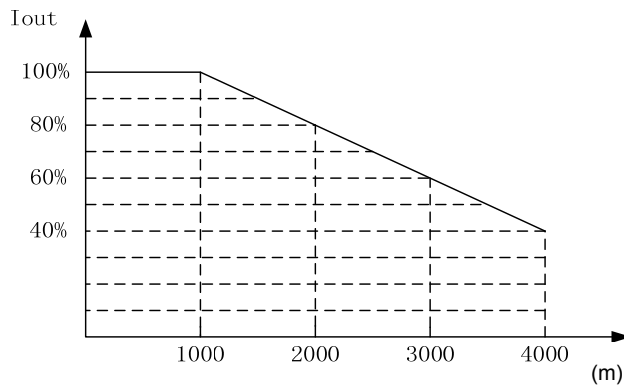

Figure 3.1 Relationship between output current and altitude.

3.1.4 Impact and Oscillation

It is not allowed that the inverter falls down or suffers from fierce impact or the inverter installed at the place that oscillation frequently.

3.1.5 Electromagnetic Radiation

Keep away from the electromagnetic radiation source.

3.1.6 Water

Do not install the inverter at the wringing or dewfall place.

3.1.7 Air Pollution

Keep away from air pollution such as dusty, corrosive gas.

3.1.8 Storage

Do not store the inverter in the environment with direct sunlight, vapor, oil fog and vibration.

3.2 Installation Space

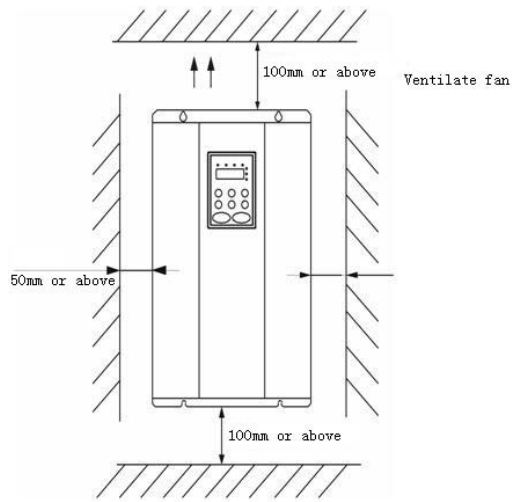

Figure 3.2 Safety space.

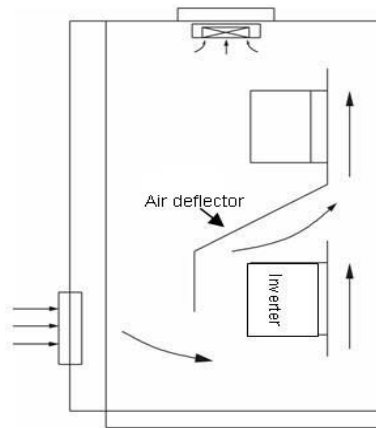

Figure 3.3 Installation of multiple inverters.

Notice: Add the air deflector when apply the up-down installation.

3.3 Dimensions of External Keypad

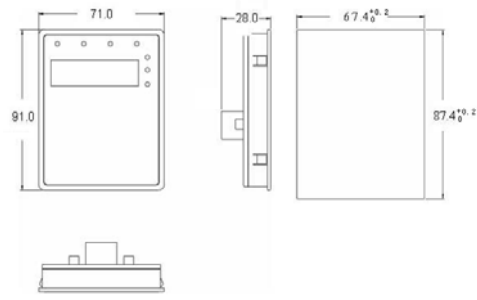

Figure 3.4 Dimension of small keypad.

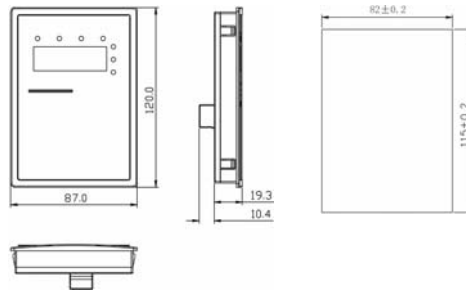

Figure 3.5 Dimension of big keypad.

3.4 Disassembly

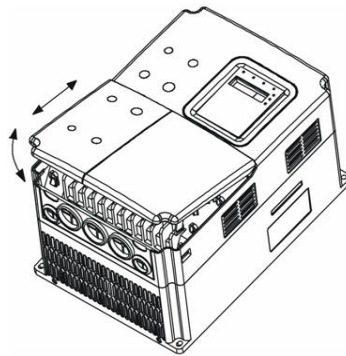

Figure 3.6 Disassembly of plastic cover.

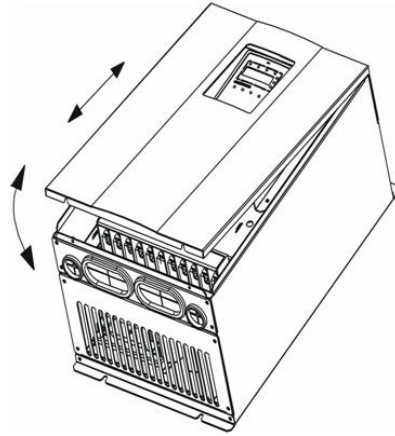

Figure 3.7 Disassembly of metal plate cover.

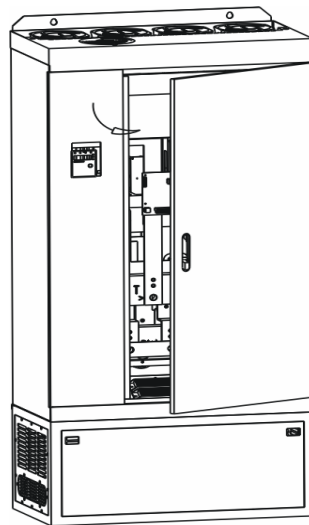

Figure 3.8 Open inverter cabinet.

4. WIRING



WARNING

- Wiring must be performed by the person certified in electrical work.
- Forbid testing the insulation of cable that connects the inverter with high-voltage insulation testing devices.
- Cannot install the inverter until discharged completely after the power supply is switched off for 5 minutes.
- Be sure to ground the ground terminal.
(200V class: Ground resistance should be 100Ω or less, 400V class: Ground resistance should be 10Ω or less, 660V class: Ground resistance should be 5Ω or less). Otherwise, it might cause electric shock or fire.
- Connect input terminals (R, S, T) and output terminals (U, V, W) correctly.
Otherwise it will cause damage the inside part of inverter.
- Do not wire and operate the inverter with wet hands.
Otherwise there is a risk of electric shock.



CAUTION

- Check to be sure that the voltage of the main AC power supply satisfies the rated voltage of the Inverter.
Injury or fire can occur if the voltage is not correct.
- Connect power supply cables and motor cables tightly.

4.1 Connection of Peripheral Devices

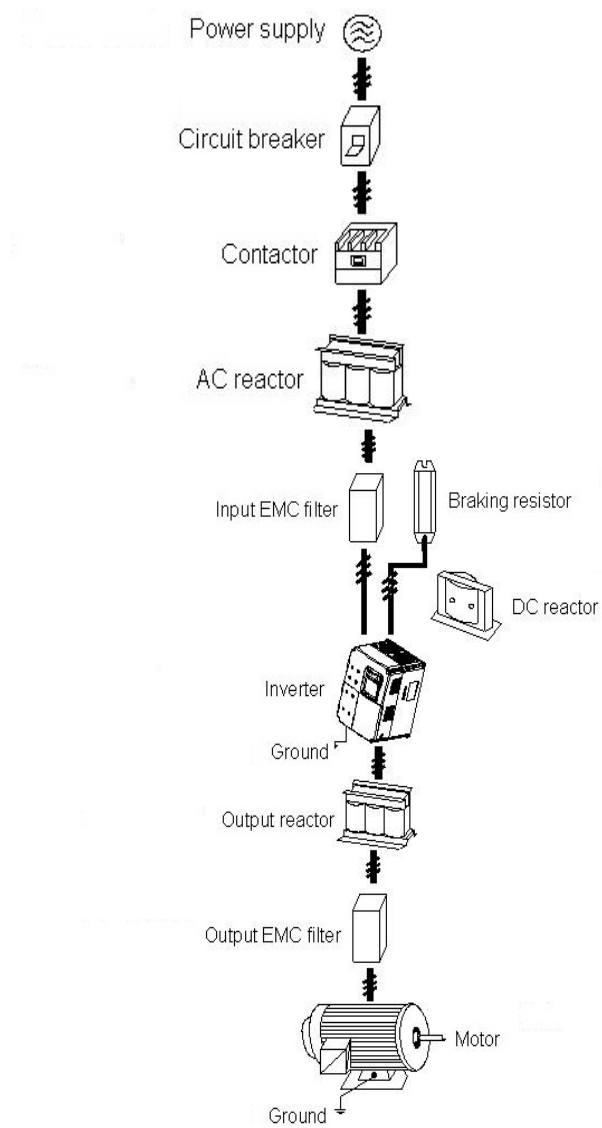

Figure 4.1 Connection of peripheral devices.

4.2 Terminal Configuration

4.2.1 Main Circuit Terminals (380VAC)

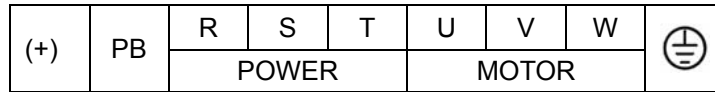

Figure 4.2 Main circuit terminals (1.5~2.2kW).

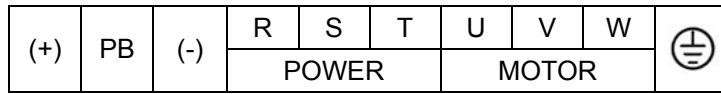

Figure 4.3 Main circuit terminals (4~5.5kW).

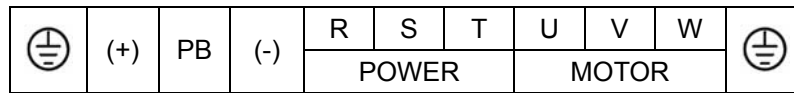

Figure 4.4 Main circuit terminals (7.5~15kW).

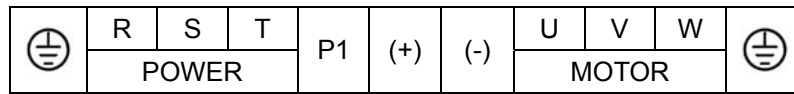

Figure 4.5 Main circuit terminals (18.5~110kW).

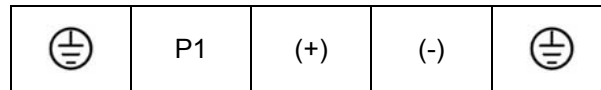
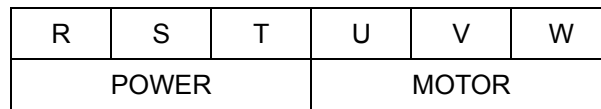

Figure 4.6 Main circuit terminals (132~315kW).

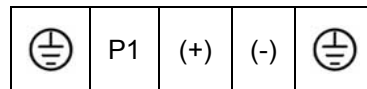
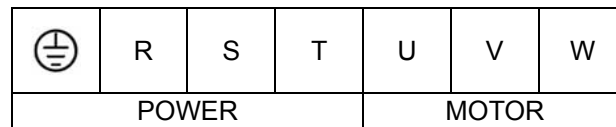



Figure 4.7 Main circuit terminals (350~630kW).

Main circuit terminal functions are summarized according to the terminal symbols in the following table. Wire the terminal correctly for the desired purposes.

Terminal Symbol	Function Description
R、S、T	Terminals of 3 phase AC input
(+)、(-)	Spare terminals of external braking unit
(+)、PB	Spare terminals of external braking resistor
P1、(+)	Spare terminals of external DC reactor
(-)	Terminal of negative DC bus
U、V、W	Terminals of 3 phase AC output
	Terminal of ground

4.2.2 Control Circuit Terminals

485+	485-	+10V	S1	S2	S3	S4	HDI		ROA	ROA
AI1	AI2	GND	AO	COM	HDO	PW	+24V		ROB	ROC

Figure 4.8 Control circuit terminals (1.5~2.2kW).

485+	485-	+10V	S1	S2	S3	S4	HDI		RO1A	RO1A	RO1C
AI1	AI2	GND	AO	COM	HDO	PW	+24V		RO2B	RO2C	RO2C

Figure 4.9 Control circuit terminals (4kW and above).

4.3 Typical Wiring Diagram

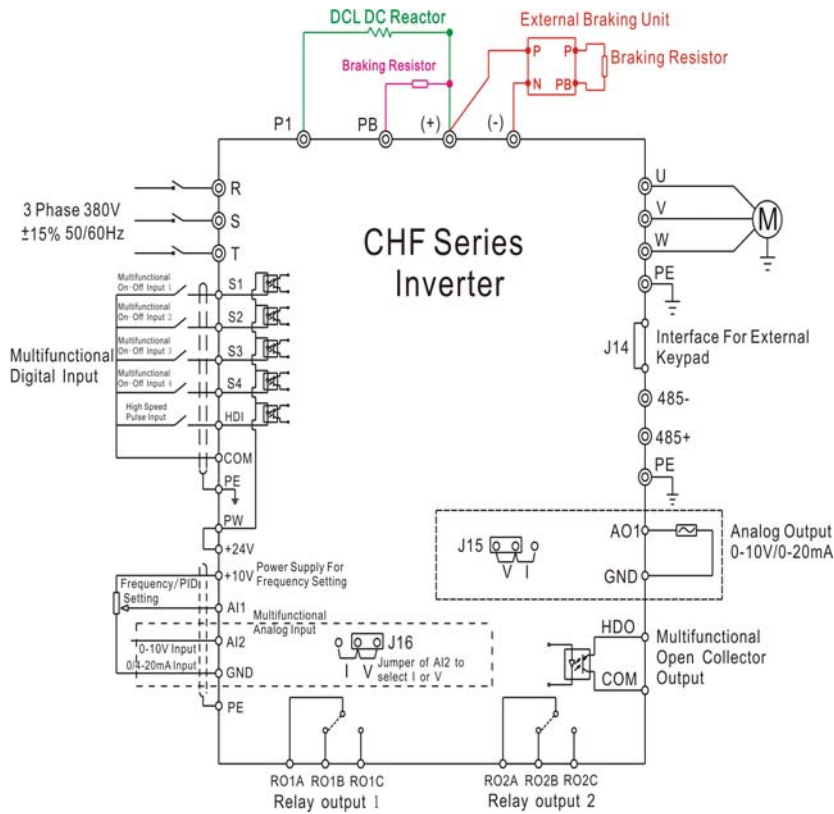

Figure4. 10 Wiring diagram.

Notice:

- Inverters between 18.5KW and 90KW have built-in DC reactor which is used to improve power factor. For inverters above 110KW, it is recommended to install DC reactor between P1 and (+).
- The inverters below 18.5KW have build-in braking unit. If need braking, only need to install braking resistor between PB and (+).
- For inverters above (including) 18.5KW, if need braking, should install external braking unit between (+) and (-).
- Only the inverters above 4 KW provide Relay output 2.
- +24V connect with PW as default setting. If user need external power supply, disconnect +24V with PW and connect PW with external power supply.
- 485+ and 485- are optional for 485 communications.

4.4 Specifications of Breaker, Cable, Contactor and Reactor

4.4.1 Specifications of breaker, cable and contactor

Model No.	Circuit Breaker (A)	Input/Output Cable (mm ²)	AC Contactor (A)
1AC 220V ± 15%			
CHF100-1R5G-S2	20	4	16
CHF100-2R2G-S2	32	6	20
3AC 220V ± 15%			
CHF100-0R4G-2	16	2.5	10
CHF100-0R7G-2	16	2.5	10
CHF100-1R5G-2	20	4	16
CHF100-2R2G-2	32	6	20
CHF100-004G-2	40	6	25
CHF100-5R5G-2	63	6	32
CHF100-7R5G-2	100	10	63
CHF100-011G-2	125	25	95
CHF100-015G-2	160	25	120
CHF100-018G-2	160	25	120
CHF100-022G-2	200	35	170
CHF100-030G-2	200	35	170
CHF100-037G-2	200	35	170
CHF100-045G-2	250	70	230
3AC 380V ± 15%			
CHF100-0R7G-4	10	2.5	10
CHF100-1R5G-4	16	2.5	10
CHF100-2R2G-4	16	2.5	10
CHF100-004G/5R5P-4	25	4	16
CHF100-5R5G/7R5P-4	25	4	16
CHF100-7R5G/011P-4	40	6	25
CHF100-011G/015P-4	63	6	32
CHF100-015G/018P-4	63	6	50
CHF100-018G/022P-4	100	10	63
CHF100-022G/030P-4	100	16	80
CHF100-030G/037P-4	125	25	95
CHF100-037G/045P-4	160	25	120
CHF100-045G/055P-4	200	35	135
CHF100-055G/075P-4	200	35	170

CHF100-075G/090P-4	250	70	230
CHF100-090G/110P-4	315	70	280
CHF100-110G/132P-4	400	95	315
CHF100-132G/160P-4	400	150	380
CHF100-160G/185P-4	630	185	450
CHF100-185G/200P-4	630	185	500
CHF100-200G/220P-4	630	240	580
CHF100-220G/250P-4	800	150x2	630
CHF100-250G/280P-4	800	150x2	700
CHF100-280G/315P-4	1000	185x2	780
CHF100-315G/350P-4	1200	240x2	900

4.4.2 Specifications of AC input/output reactor and DC reactor

Model No.	AC Input reactor		AC Output reactor		DC reactor	
	Current (A)	Inductance (mH)	Current (A)	Inductance (mH)	Current (A)	Inductance (mH)
CHF100-0R7G-4	—	—	—	—	—	—
CHF100-1R5G-4	5	3.8	5	1.5	—	—
CHF100-2R2G-4	7	2.5	7	1	—	—
CHF100-004G/5R5P-4	10	1.5	10	0.6	—	—
CHF100-5R5G/7R5P-4	15	1.4	15	0.25	—	—
CHF100-7R5G/011P-4	20	1	20	0.13	—	—
CHF100-011G/015P-4	30	0.6	30	0.087	—	—
CHF100-015G/018P-4	40	0.6	40	0.066	—	—
CHF100-018G/022P-4	50	0.35	50	0.052	40	1.3
CHF100-022G/030P-4	60	0.28	60	0.045	50	1.08
CHF100-030G/037P-4	80	0.19	80	0.032	65	0.8
CHF100-037G/045P-4	90	0.19	90	0.03	78	0.7
CHF100-045G/055P-4	120	0.13	120	0.023	95	0.54
CHF100-055G/075P-4	150	0.11	150	0.019	115	0.45
CHF100-075G/090P-4	200	0.12	200	0.014	160	0.36
CHF100-090G/110P-4	250	0.06	250	0.011	180	0.33
CHF100-110G/132P-4	250	0.06	250	0.011	250	0.26

CHF100-132G/160P-4	290	0.04	290	0.008	250	0.26
CHF100-160G/185P-4	330	0.04	330	0.008	340	0.18
CHF100-185G/200P-4	400	0.04	400	0.005	460	0.12
CHF100-200G/220P-4	490	0.03	490	0.004	460	0.12
CHF100-220G/250P-4	490	0.03	490	0.004	460	0.12
CHF100-250G/280P-4	530	0.04	530	0.005	650	0.11
CHF100-280G/315P-4	600	0.04	600	0.005	650	0.11
CHF100-315G/350P-4	660	0.02	660	0.002	800	0.06

4.4.3 Specifications of braking unit and braking resistor

Model No.	Braking unit		Braking resistor	
	Order No.	Quantity	Specification	Quantity
3AC 220V \pm 15%				
CHF100-0R4G-2	Built-in	1	275 Ω /75W	1
CHF100-0R7G-2			275 Ω /75W	1
CHF100-1R5G-2			130 Ω /260W	1
CHF100-2R2G-2			80 Ω /260W	1
CHF100-004G-2			48 Ω /400W	1
CHF100-5R5G-2			35 Ω /550W	1
CHF100-7R5G-2	DBU-055-2	1	26 Ω /780W	1
CHF100-011G-2			17 Ω /1100W	1
CHF100-015G-2			13 Ω /1800W	1
CHF100-018G-2			10 Ω /2200W	1
CHF100-022G-2			8 Ω /2500W	1
CHF100-030G-2	DBU-055-2	2	13 Ω /1800W	2
CHF100-037G-2			10 Ω /2200W	2
CHF100-045G-2			8 Ω /2500W	2
3AC 380V \pm 15%				
CHF100-0R7G-4	Built-in	1	900 Ω /75W	1
CHF100-1R5G-4			400 Ω /260W	1
CHF100-2R2G-4			150 Ω /390W	1
CHF100-004G/5R5P-4				

CHF100-5R5G/7R5P-4			100Ω/520W	1
CHF100-7R5G/011P-4			50Ω/1040W	1
CHF100-011G/015P-4			40Ω/1560W	1
CHF100-015G/018P-4				
CHF100-018G/022P-4	DBU-055-4	1	20Ω/6000W	1
CHF100-022G/030P-4				
CHF100-030G/037P-4				
CHF100-037G/045P-4				
CHF100-045G/055P-4				
CHF100-055G/075P-4			13.6Ω/9600W	1
CHF100-075G/090P-4	DBU-055-4	2	13.6Ω/9600W	2
CHF100-090G/110P-4				
CHF100-110G/132P-4				
CHF100-132G/160P-4	DBU-160-4	1	4Ω/30000W	1
CHF100-160G/185P-4				
CHF100-185G/200P-4	DBU-220-4	1	3Ω/40000W	1
CHF100-200G/220P-4				
CHF100-220G/250P-4				
CHF100-250G/280P-4	DBU-315-4	1	3Ω/40000W	2
CHF100-280G/315P-4				
CHF100-315G/350P-4				

Notice:

1. Above selection is based on following condition:
100% braking torque, 10% usage rate.
2. Brake threshold voltage: 700V (380V inverter), 370V (220V inverter)
3. Parallel connection of braking unit is helpful to improve braking capability.
4. Wire between inverter and braking unit should be less than 5m.
5. Wire between braking unit and braking resistor should be less than 10m.
6. Braking unit can be used for braking continuously for 5 minutes. When braking unit is working, temperature of cabinet will be high, user is not allowed to touch to prevent from injure.

For more details, please refer to DBU and RBU user manual.

4.5 Wiring Main Circuits

4.5.1 Wiring at input side of main circuit

4.5.1.1 Circuit breaker

It is necessary to connect a circuit breaker which is compatible with the capacity of inverter between 3ph AC power supply and power input terminals (R, S, T). The capacity of breaker is 1.5~2 times to the rated current of inverter. For details, see <Specifications of Breaker, Cable, and Contactor>.

4.5.1.2 Contactor

In order to cut off the input power effectively when something is wrong in the system, contactor should be installed at the input side to control the ON-OFF of the main circuit power supply.

4.5.1.3 AC reactor

In order to prevent the rectifier damage result from the large current, AC reactor should be installed at the input side. It can also prevent rectifier from sudden variation of power voltage or harmonic generated by phase-control load.

4.5.1.4 Input EMC filter

The surrounding device may be disturbed by the cables when the inverter is working. EMC filter can minimize the interference. Just like the following figure.

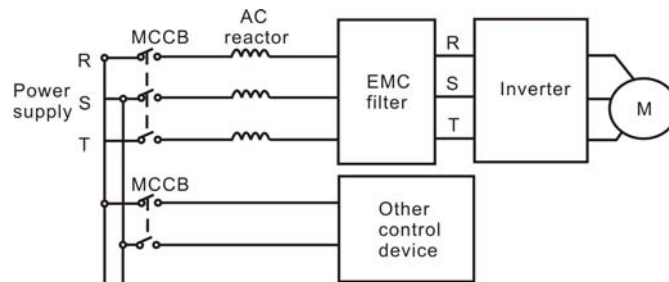

Figure4.11 Wiring at input side.

4.5.2 Wiring at inverter side of main circuit

4.5.2.1 DC reactor

Inverters from 18.5kW to 90kW have built-in DC reactor which can improve the power factor,

4.5.2.2 Braking unit and braking resistor

- Inverter of 15KW and below have built-in braking unit. In order to dissipate the regenerative energy generated by dynamic braking, the braking resistor should be installed at (+) and PB terminals. The wire length of the braking resistor should be less than 5m.
- Inverter of 18.5KW and above need connect external braking unit which should be installed at (+) and (-) terminals. The cable between inverter and braking unit should be less than 5m. The cable between braking unit and braking resistor should be less than 10m.
- The temperature of braking resistor will increase because the regenerative energy will be transformed to heat. Safety protection and good ventilation is recommended.

Notice: Be sure that the electric polarity of (+) (-) terminals is right; it is not allowed to connect (+) with (-) terminals directly, Otherwise damage or fire could occur.

4.5.3 Wiring at motor side of main circuit

4.5.3.1 Output Reactor

When the distance between inverter and motor is more than 50m, inverter may be tripped by over-current protection frequently because of the large leakage current resulted from the parasitic capacitance with ground. And the same time to avoid the damage of motor insulation, the output reactor should be installed.

4.5.3.2 Output EMC filter

EMC filter should be installed to minimize the leakage current caused by the cable and minimize the radio noise caused by the cables between the inverter and cable. Just see the following figure.

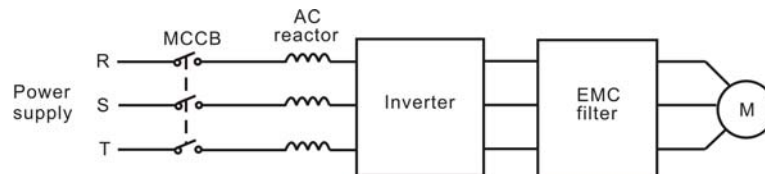

Figure 4.12 Wiring at motor side.

4.5.4 Wiring of regenerative unit

Regenerative unit is used for putting the electricity generated by braking of motor to the grid. Compared with traditional 3 phase inverse parallel bridge type rectifier unit, regenerative unit uses IGBT so that the total harmonic distortion (THD) is less than 4%. Regenerative unit is widely used for centrifugal and hoisting equipment.

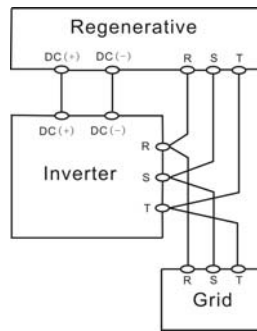

Figure 4.13 Wiring of regenerative unit.

4.5.5 Wiring of Common DC bus

Common DC bus method is widely used in the paper industry and chemical fiber industry which need multi-motor to coordinate. In these applications, some motors are in driving status while some others are in regenerative braking (generating electricity) status. The regenerated energy is automatically balanced through the common DC bus, which means it can supply to motors in driving status. Therefore the power consumption of whole system will be less compared with the traditional method (one inverter drives one motor). When two motors are running at the same time (i.e. winding application), one is in driving status and the other is in regenerative status. In this case the DC buses of these two inverters can be connected in parallel so that the regenerated energy can be supplied to motors in driving status whenever it needs. Its detailed wiring is shown in the following figure:

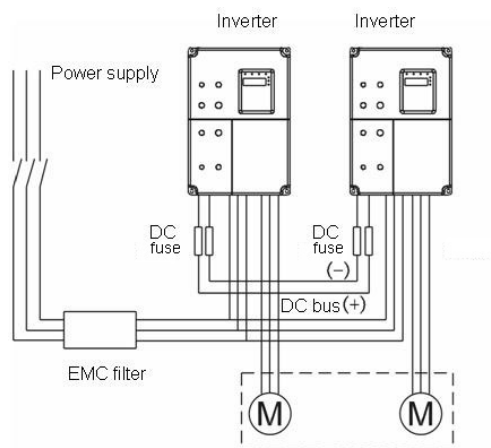

Figure 4.14 Wiring of common DC bus.

Notice: Two inverters must be the same model when connected with Common DC bus method. Be sure they are powered on at the same time.

4.5.6 Ground Wiring (PE)

In order to ensure safety and prevent electrical shock and fire, terminal PE must be grounded with ground resistance. The ground wire should be big and short, and it is better to use copper wire ($>3.5\text{mm}^2$). When multiple inverters need to be grounded, do not loop the ground wire.

4.6 Wiring Control Circuit

4.6.1 Precautions

4.6.1.1 Use shielded or twisted-pair cables to connect control terminals.

4.6.1.2 Connect the ground terminal (PE) with shield wire.

4.6.1.3 The cable connected to the control terminal should leave away from the main circuit and heavy current circuits (including power supply cable, motor cable, relay and contactor connecting cable) at least 20cm and parallel wiring should be avoided. It is suggested to apply perpendicular wiring to prevent inverter malfunction caused by external interference.

4.6.2 Control circuit terminals

Terminal	Description
S1~S4	ON-OFF signal input, optical coupling with PW and COM. Input voltage range: 9~30V Input impedance: 3.3k Ω
HDI	High speed pulse or ON-OFF signal input, optical coupling with PW and COM. Pulse input frequency range: 0~50kHz Input voltage range: 9~30V Input impedance: 1.1k Ω
PW	External power supply. +24V terminal is connected to PW terminal as default setting. If user need external power supply, disconnect +24V terminal with PW terminal and connect PW terminal with external power supply.
+24V	Provide output power supply of +24V. Maximum output current: 150mA
AI1	Analog input, 0~10V Input impedance: 10k Ω
AI2	Analog input, 0~10V/ 0~20mA, switched by J16. Input impedance: 10k Ω (voltage input) / 250 Ω (current input)

Terminal	Description
GND	Common ground terminal of analog signal and +10V. GND must isolated from COM.
+10V	Supply +10V for inverter.
HDO	High speed pulse output terminal. The corresponding common ground terminal is COM. Output frequency range: 0~50 kHz
COM	Common ground terminal for digital signal and +24V (or external power supply).
AO	Provide voltage or current output which can be switched by J15. Output range: 0~10V/ 0~20mA
RO1A、 RO1B、 RO1C	RO1 relay output: RO1A—common; RO1B—NC; RO1C—NO. Contact capacity: AC 250V/3A, DC 30V/1A.
RO2A、 RO2B、 RO2C	RO2 relay output: RO2A—common; RO2B—NC; RO2C—NO. Contact capacity: AC 250V/3A, DC 30V/1A.

4.6.3 Jumper on control board

Jumper	Description
J2, J4	It is prohibited to be connected together, otherwise it will cause inverter malfunction.
J7	Default setting: 2 and 3 connected. Do not change default setting otherwise it will cause communication malfunction.
J16	Switch between (0~10V) voltage input and (0~20mA) current input. V connect to GND means voltage input; I connect to GND means current input.
J15	Switch between (0~10V) voltage output and (0~20mA) current output. V connect to OUT means voltage output; I connect to OUT means current output.
S1	Switch of terminal resistor for RS485 communication. ON: Connect to terminal resistor. OFF: Disconnect to terminal resistor. (Valid for inverter of 4.0KW or above)
J17, J18	Switch of terminal resistor for RS485 communication. Jumper enable: Connect terminal resistor. Jumper disable: Disconnect terminal resistor. (Valid for inverter of 1.5~2.2kW).

4.7 Installation Guideline to EMC Compliance

4.7.1 General knowledge of EMC

EMC is the abbreviation of electromagnetic compatibility, which means the device or system has the ability to work normally in the electromagnetic environment and will not generate any electromagnetic interference to other equipments.

EMC includes two subjects: electromagnetic interference and electromagnetic anti-jamming.

According to the transmission mode, Electromagnetic interference can be divided into two categories: conducted interference and radiated interference.

Conducted interference is the interference transmitted by conductor. Therefore, any conductors (such as wire, transmission line, inductor, capacitor and so on) are the transmission channels of the interference.

Radiated interference is the interference transmitted in electromagnetic wave, and the energy is inverse proportional to the square of distance.

Three necessary conditions or essentials of electromagnetic interference are: interference source, transmission channel and sensitive receiver. For customers, the solution of EMC problem is mainly in transmission channel because of the device attribute of disturbance source and receiver can not be changed.

4.7.2 EMC features of inverter

Like other electric or electronic devices, inverter is not only an electromagnetic interference source but also an electromagnetic receiver. The operating principle of inverter determines that it can produce certain electromagnetic interference noise. At the same time inverter should be designed with certain anti-jamming ability to ensure the smooth working in certain electromagnetic environment. Following is its EMC features:

- 4.7.2.1 Input current is non-sine wave. The input current includes large amount of high-harmonic waves that can cause electromagnetic interference, decrease the grid power factor and increase the line loss.
- 4.7.2.2 Output voltage is high frequency PWM wave, which can increase the temperature rise and shorten the life of motor. And the leakage current will also increase, which can lead to the leakage protection device malfunction and generate strong electromagnetic interference to influence the reliability of other electric devices.
- 4.7.2.3 As the electromagnetic receiver, too strong interference will damage the inverter and influence the normal using of customers.
- 4.7.2.4 In the system, EMS and EMI of inverter coexist. Decrease the EMI of inverter can increase its EMS ability.

4.7.3 EMC Installation Guideline

In order to ensure all electric devices in the same system to work smoothly, this section, based on EMC features of inverter, introduces EMC installation process in several aspects of application (noise control, site wiring, grounding, leakage current and power supply filter). The good effective of EMC will depend on the good effective of all of these five aspects.

4.7.3.1 Noise control

All the connections to the control terminals must use shielded wire. And the shield layer of the wire must ground near the wire entrance of inverter. The ground mode is 360 degree annular connection formed by cable clips. It is strictly prohibitive to connect the twisted shielding layer to the ground of inverter, which greatly decreases or loses the shielding effect.

Connect inverter and motor with the shielded wire or the separated cable tray. One side of shield layer of shielded wire or metal cover of separated cable tray should connect to ground, and the other side should connect to the motor cover. Installing an EMC filter can reduce the electromagnetic noise greatly.

4.7.3.2 Site wiring

Power supply wiring: the power should be separated supplied from electrical transformer. Normally it is 5 core wires, three of which are fire wires, one of which is the neutral wire, and one of which is the ground wire. It is strictly prohibitive to use the same line to be both the neutral wire and the ground wire

Device categorization: there are different electric devices contained in one control cabinet, such as inverter, filter, PLC and instrument etc, which have different ability of emitting and withstanding electromagnetic noise. Therefore, it needs to categorize these devices into strong noise device and noise sensitive device. The same kinds of device should be placed in the same area, and the distance between devices of different category should be more than 20cm.

Wire Arrangement inside the control cabinet: there are signal wire (light current) and power cable (strong current) in one cabinet. For the inverter, the power cables are categorized into input cable and output cable. Signal wires can be easily disturbed by power cables to make the equipment malfunction. Therefore when wiring, signal cables and power cables should be arranged in different area. It is strictly prohibitive to arrange them in parallel or interlacement at a close distance (less than 20cm) or tie them together. If the signal wires have to cross the power cables, they should be arranged in 90 angles. Power input and output cables should not either be arranged in interlacement or tied together, especially when installed the EMC filter. Otherwise the distributed capacitances

of its input and output power cable can be coupling each other to make the EMC filter out of function.

4.7.3.3 Ground

Inverter must be ground safely when in operation. Grounding enjoys priority in all EMC methods because it does not only ensure the safety of equipment and persons, but also is the simplest, most effective and lowest cost solution for EMC problems.

Grounding has three categories: special pole grounding, common pole grounding and series-wound grounding. Different control system should use special pole grounding, and different devices in the same control system should use common pole grounding, and different devices connected by same power cable should use series-wound grounding.

4.7.3.4 Leakage Current

Leakage current includes line-to-line leakage current and over-ground leakage current. Its value depends on distributed capacitances and carrier frequency of inverter. The over-ground leakage current, which is the current passing through the common ground wire, can not only flow into inverter system but also other devices. It also can make leakage current circuit breaker, relay or other devices malfunction. The value of line-to-line leakage current, which means the leakage current passing through distributed capacitors of input output wire, depends on the carrier frequency of inverter, the length and section areas of motor cables. The higher carrier frequency of inverter, the longer of the motor cable and/or the bigger cable section area, the larger leakage current will occur.

Countermeasure:

Decreasing the carrier frequency can effectively decrease the leakage current. In the case of motor cable is relatively long (longer than 50m), it is necessary to install AC reactor or sinusoidal wave filter at the output side, and when it is even longer, it is necessary to install one reactor at every certain distance.

4.7.3.5 EMC Filter

EMC filter has a great effect of electromagnetic decoupling, so it is preferred for customer to install it.

For inverter, noise filter has following categories:

- Noise filter installed at the input side of inverter;
- Install noise isolation for other equipment by means of isolation transformer or power filter.

5. OPERATION

5.1 Keypad Description

5.1.1 Keypad schematic diagram

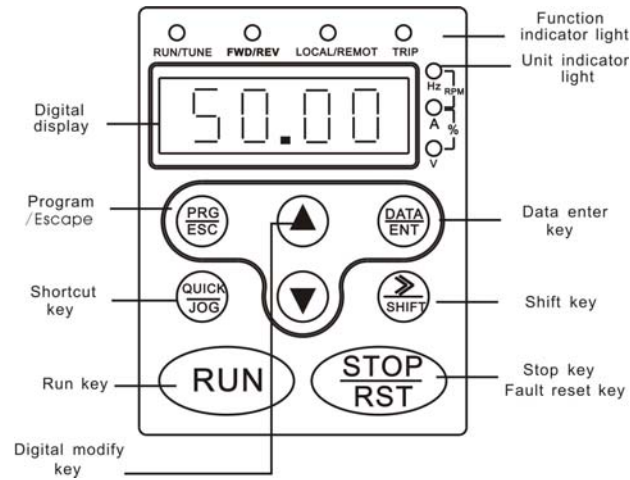



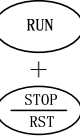

Figure 5.1 Keypad schematic diagram.

5.1.2 Function key description

Key	Name	Function Description
	Programming Key	Entry or escape of first-level menu.
	Enter Key	Progressively enter menu and confirm parameters.
	UP Increment Key	Progressively increase data or function codes.
	DOWN Decrement Key	Progressive decrease data or function codes.
	Combination Key	Cyclically displays parameters by left shift, In the stop or running status. Note that when operation, should firstly press and hold the DATA/ENT key and then press the QUICK/JOG key.

	Shift Key	In parameter setting mode, press this button to select the bit to be modified. In other modes, cyclically displays parameters by right shift
	Run Key	Start to run the inverter in keypad control mode.
	STOP/RESET Key	In running status, restricted by P7.04, can be used to stop the inverter. When fault alarm, can be used to reset the inverter without any restriction.
	Shortcut Key	Determined by Function Code P7.03: 0: Jog operation 1: Switch between forward and reverse 2: Clear the UP/DOWN settings. 3: Quick debugging mode1 (by menu) 4: Quick debugging mode2 (by latest order) 5: Quick debugging mode3 (by non-factory setting parameters)
	Combination Key	Pressing the RUN and STOP/REST at the same time can achieve inverter coast to stop.

5.1.3 Indicator light description

5.1.3.1 Function Indicator Light Description

Function indicator	Description
RUN/TUNE	Extinguished: stop status Flickering: parameter autotuning status Light on: operating status
FWD/REV	Extinguished: forward operation Light on: reverse operation.
LOCAL/REMOT	Extinguished: keypad control Flickering: terminal control Light on: communication control
TRIP	Extinguished: normal operation status Flickering: overload pre-warning status

5.1.3.2 Unit Indicator Light Description

Unit indicator	Description
Hz	Frequency unit
A	Current unit
V	Voltage unit
RPM	Rotating speed unit
%	Percentage

5.1.3.3 Digital Display

Have 5 digit LED , which can display all kinds of monitoring data and alarm codes such as reference frequency, output frequency and so on.

5.2 Operation Process

5.2.1 Parameter setting

Three levels of menu are:

- Function code group (first-level);
- Function code (second-level);
- Function code value (third-level).

Remarks:

Press both the **PRG/ESC** and the **DATA/ENT** can return to the second-class menu from the third-class menu. The difference is: pressing **DATA/ENT** will save the set parameters into the control panel, and then return to the second-class menu with shifting to the next function code automatically; while pressing **PRG/ESC** will directly return to the second-class menu without saving the parameters, and keep staying at the current function code.

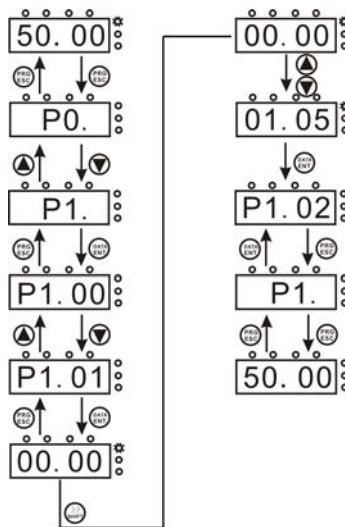

Figure 5.2 Flow chart of parameter setting.

Under the third-class menu, if the parameter has no flickering bit, it means the function code cannot be modified. The possible reasons could be:

- This function code is not modifiable parameter, such as actual detected parameter, operation records and so on;
- This function code is not modifiable in running status, but modifiable in stop status.

5.2.2 Fault reset

If the inverter has fault, it will prompt the related fault information. User can use **STOP/RST** or according terminals determined by P5 Group to reset the fault. After fault reset, the inverter is at stand-by state. If user does not reset the inverter when it is at fault state, the inverter will be at operation protection state, and can not run.

5.2.3 Motor parameters autotuning

The procedure of motor parameter autotuning is as follows:

Firstly, choose the keypad command channel as the operation command channel (P0.01).

And then input following parameters according to the actual motor parameters:

- P2.00: motor rated power.
- P2.01: motor rated frequency;
- P2.02: motor rated speed;
- P2.03: motor rated voltage;
- P2.04: motor rated current;

Notice: the motor should be uncoupled with its load; otherwise, the motor parameters obtained by autotuning may be not correct. Set P0.12 to be 1, and for the detail process of motor parameter autotuning, please refer to the description of Function Code P0.12.

And then press **RUN** on the keypad panel, the inverter will automatically calculate following parameter of the motor:

- P2.05: motor stator resistance;
 - P2.06: motor rotor resistance;
 - P2.07: motor stator and rotor inductance;
 - P2.08: motor stator and rotor mutual inductance;
 - P2.09: motor current without load;
- then motor autotuning is finished.

5.2.4 Password setting

CHF series inverter offers user's password protection function. When P7.00 is set to be nonzero, it will be the user's password, and After exiting function code edit mode, it will become effective after 1 minute. If pressing the **PRG/ESC** again to try to access the function code edit mode, "0.0.0.0.0" will be displayed, and the operator must input correct user's password, otherwise will be unable to access it.

If it is necessary to cancel the password protection function, just set P7.00 to be zero.

5.2.5 Shortcut menu setting

Shortcut menu, in which parameters in common use can be programmed, provides a quick way to view and modify function parameters. In the shortcut menu, a parameter being displayed as "hP0.11" means the function parameter P0.11. Modifying parameters in the shortcut menu has the same effect as doing at normal programming status.

Maximum 16 function parameters can be saved into the shortcut menu, and these parameters can be added or deleted when P7.03 is set to be 0.

5.3 Running State

5.3.1 Power-on initialization

Firstly the system initializes during the inverter power-on, and LED displays "8888". After the initialization is completed, the inverter is in stand-by status

5.3.2 Stand-by

At stop or running status, parameters of multi-status can be displayed. Whether or not to display this parameter can be chosen through Function Code P7.06, P7.07 (Running status display selection) and P7.08 (Stop status display selection) according to binary bits, the detailed description of each bit please refer the function code description of P7.06, P7.07 and P7.08.

In stop status, there are ten parameters which can be chosen to display or not. They are: reference frequency, DC bus voltage, ON-OFF input status, open collector output status, PID setting, PID feedback, analog input AI1 voltage, analog input AI2 voltage, HDI frequency, step number of simple PLC and multi-step speed. Whether or not to display can be determined by setting the corresponding binary bit of P7.08. Press the **»/SHIFT** to scroll through the parameters in right order. Press **DATA/ENT** + **QUICK/JOG** to scroll through the parameters in left order.

5.3.3 Motor parameters autotuning

For details, please refer to the description of Function Code P0.12.

5.3.4 Operation

In running status, there are twenty two running parameters which can be chosen to display or not. They are: running frequency, reference frequency, DC bus voltage, output voltage, output current, rotating speed, line speed, output power, output torque, PID setting, PID feedback, ON-OFF input status, open collector output status, length value, count value, step number of PLC and multi-step speed, voltage of AI1, voltage of AI2, high speed pulse input HDI frequency. Whether or not to display can be determined by setting the corresponding bit of P7.06, P7.07. Press the **»/SHIFT** to scroll through the parameters in right order. Press **DATA/ENT** + **QUICK/JOG** to scroll through the parameters in left order.

5.3.5 Fault

In fault status, inverter will display parameters of STOP status besides parameters of fault status. Press the **»/SHIFT** to scroll through the parameters in right order . Press **DATA/ENT** + **QUICK/JOG** to scroll through the parameters in left order.

CHF series inverter offers a variety of fault information. For details, see inverter faults and their troubleshooting .

5.4 Shortcut Menu

Shortcut menu provides a quick way to view and modify function parameters. CHF inverter provided three kinds of shortcut menu.

5.4.1 Shortcut menu operation

Shortcut menu has two levels of menus, which are corresponding to the second-level and the third-level menus of general menu, and has no corresponding with first-level menu.

Remarks:

In stop or running status, press **QUICK/JOG** to enter the shortcut first-level menu, use **UP/DOWN** to select different shortcut parameter, and then press **DATA/ENT** to enter the shortcut second-level menu. The method to modify parameter at the shortcut second-level menu is the same as that at the general third-level menu. If want to return to last display, press **QUICK/JOG**.

The operation example is as following:

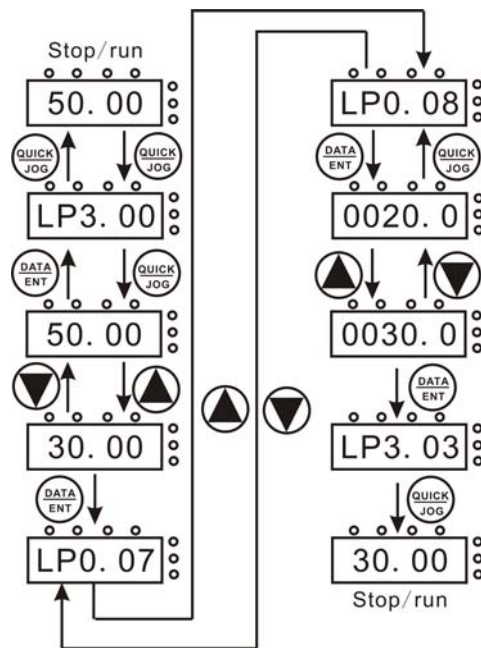

Figure 5.3 Shortcut menu operation.

5.4.2 Quick debugging mode

5.4.2.1 Quick debugging mode 1

The user can select the shortcut debug mode 1 by set P7.03 to be 3. This parameter is set by factory and the parameter setting is in the following table.

Serial No.	Function Code	Name	Description	Setting Range	Factory setting
1	P3.00	Keypad reference frequency	0.00 Hz ~ P0.04	0.00~P0.04	50.00Hz
2	P0.07	Acceleration time 0	0.0~3600.0s	0.0~3600.0	Depend on model
3	P0.08	Deceleration time 0	0.0~3600.0s	0.0~3600.0	Depend on model
4	P0.03	Run command source	0:Keypad (LED extinguish) 1:Terminal (LED flickers) 2:Communication (LED lights up)	0~2	0
5	P3.01	Frequency command source A	0: Keypad 1: Analog AI1 2: Analog AI2 3: HDI 4:Simple PLC 5. Multi-Step speed 6: PID 7: Communication	0~7	0
6	P0.11	Carrier frequency	0.5~15.0kHz	0.5~15.0	Depend on model
7	P0.09	V/F curve setting	0:Linear curve 1: User-defined curve 2: Torque_stepdown curve (1.3 order) 3: Torque_stepdown curve (1.7 order) 4: Torque_stepdown curve (2.0 order)	0~4	0
8	P0.10	Torque boost	0.0%: auto 0.1% ~ 10.0%	0.0~10.0	0.0%
9	P1.00	Start mode	0: start directly 1: DC braking and start 2: Speed tracking and start	0~2	0
10	P1.06	Stop mode	0: Deceleration to stop 1: Coast to stop	0~1	0
11	P2.01	Motor rated frequency	0.01Hz~P0.04	0.01~P0.04	50.00HZ
12	P2.03	Motor rated voltage	0~2000V	0~2000	Depend on model

5.4.2.2 Quick debugging mode 2

By setting P7.03 to be 4, the user can select shortcut-debugging mode 2. In this mode, debugging and setting are conducted according to the latest modified parameters. The inverter automatically records functional parameters that the user accesses and modifies after power on. The recording sequence is the sequence in which the user accesses the parameters. The latest accessed parameter is saved in the foremost place of the shortcut menu, and the earliest accessed parameter is saved in the backmost place of the shortcut menu. The length of the shortcut menu buffer can support the storage of 16 parameters. If the number of recorded parameters exceeds 16, the earliest recorded parameters will be deleted. Press **QUICK/JOG** to enter quick debugging mode. Its debugging mode is as described in Section 5.4.1. If no parameter is modified after power on, press **QUICK/JOG**, the screen will display "NULLP", indicating that the shortcut parameter is null.

5.4.2.3 Quick debugging mode 3

By setting P7.03 to be 5, the user can select shortcut-debugging mode 3. In this mode, after the user presses **QUICK/JOG**, the inverter will automatically search current parameters that are different from default values, and the parameters will be saved in the quick debugging menu according to the sequence of the function codes for the user to view and set. The length of the shortcut menu buffer can support the storage of 16 parameters. If the number of recorded parameters exceeds 16, only the first 16 difference function codes are saved in the quick debugging menu. Press **QUICK/JOG** to enter quick debugging mode. Its debugging mode is as described in Section 5.4.1. If "NULLP" is displayed after pressing **QUICK/JOG**, it indicates that all the current parameters are the same as the default parameters.

6. DETAILED FUNCTION DESCRIPTION

6.1 P0 Group--Basic Function

Function Code	Name	Description	Setting Range	Factory Setting
P0.00	G/P option	0: G model 1: P model	0~1	0

0: Applicable to constant torque load

1: Applicable to variable torque load (i.e. fans, pumps)

CHF series inverters provide the G/P integration function. The adaptive motor power used for constant torque load (G model) should be one grade less than that used for variable torque load (P model).

To change from G model to P model, procedures are as follow:

- Set P0.00 to be 1;
- Input motor parameters in P2 group again.

Function Code	Name	Description	Setting Range	Factory Setting
P0.01	Rated power of inverter	0.4~900.0kW	0.4~900.0	Depend on model
P0.02	Rated current of inverter	0.4~2000.0A	0.0~2000.0	Depend on model

These two parameters are read only.

Function Code	Name	Description	Setting Range	Factory Setting
P0.03	Run command source	0: Keypad (LED extinguished) 1: Terminal (LED flickering) 2: Communication (LED lights on)	0~2	0

The control commands of inverter include: start, stop, forward run, reverse run, jog, fault reset and so on.

0: Keypad (LED extinguished);

Both **RUN** and **STOP/RST** key are used for running command control. If Multifunction key **QUICK/JOE** is set as FWD/REV switching function (P7.03 is set to be 1), it will be used to change the rotating orientation. **In running status, pressing **RUN** and **STOP/RST** in the same time will cause the inverter coast to stop.**

1: Terminal (LED flickering)

The operation, including forward run, reverse run, forward jog, reverse jog etc. can be controlled by multifunctional input terminals.

2: Communication (LED lights on)

The operation of inverter can be controlled by host through communication.

Detailed Function Description

Function Code	Name	Description	Setting Range	Factory Setting
P0.04	Maximum frequency	P0.05~400.00Hz	P0.05~400.00	50.00Hz

Notice:

- **The frequency reference should not exceed maximum frequency.**
- **Actual acceleration time and deceleration time are determined by maximum frequency. Please refer to description of P0.07 and P0.08.**

Function Code	Name	Description	Setting Range	Factory Setting
P0.05	Upper frequency limit	P0.06~ P0.04	P0.06~P0.04	50.00Hz

Notice:

- **Upper frequency limit should not be greater than the maximum frequency (P0.04).**
- **Output frequency should not exceed upper frequency limit.**

Function Code	Name	Description	Setting Range	Factory Setting
P0.06	Lower frequency limit	0.00 Hz ~ P0.05	0.00~P0.05	0.00Hz

Notice:

- **Lower frequency limit should not be greater than upper frequency limit (P0.05).**
- **If frequency reference is lower than P0.06, the action of inverter is determined by P1.12. Please refer to description of P1.12.**

Function Code	Name	Description	Setting Range	Factory Setting
P0.07	Acceleration time 0	0.1~3600.0s	0.1~3600.0	Depend on model
P0.08	Deceleration time 0	0.1~3600.0s	0.1~3600.0	Depend on model

Acceleration time is the time of accelerating from 0Hz to maximum frequency (P0.04).
Deceleration time is the time of decelerating from maximum frequency (P0.04) to 0Hz.
Please refer to following figure.

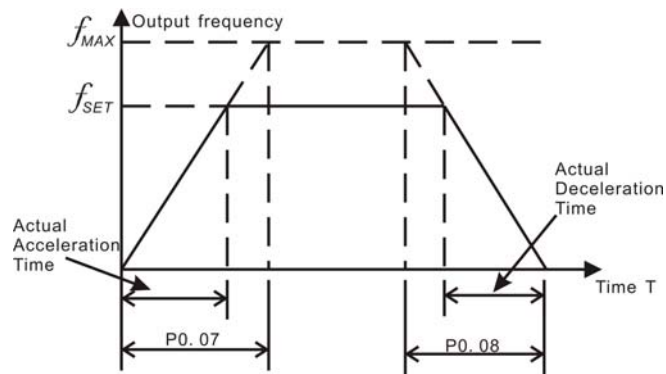

Figure 6.1 Acceleration and deceleration time.

When the reference frequency is equal to the maximum frequency, the actual acceleration and deceleration time will be equal to the P0.07 and P0.08 respectively. When the reference frequency is less than the maximum frequency, the actual acceleration and deceleration time will be less than the P0.07 and P0.08 respectively. The actual acceleration (deceleration) time = P0.07 (P0.08) * reference frequency/P0.04. CHF series inverter has 4 groups of acceleration and deceleration time.

- 1st group: P0.07, P0.08
- 2nd group: P8.00, P8.01
- 3rd group: P8.02, P8.03
- 4th group: P8.04, P8.05.

The acceleration and deceleration time can be selected by combination of multifunctional ON-OFF input terminals determined by P5 Group. The factory setting of acceleration and deceleration time is as follow:

- 5.5kW and below: 10.0s
- 7.5kW~30kW: 20.0s
- 37kW and above: 40.0s

Function Code	Name	Description	Setting Range	Factory Setting
P0.09	V/F curve selection	0: Linear curve 1: User-defined curve 2: Torque_stepdown curve (1.3 order) 3: Torque_stepdown curve (1.7 order) 4: Torque_stepdown curve (2.0 order)	0~4	0

Detailed Function Description

0: Linear curve. It is applicable for normal constant torque load.

1: User-defined curve. It can be defined through setting (P4.07~P4.12).

2~4: Torque_stepdown curve. It is applicable for variable torque load, such as blower, pump and so on. Please refer to following figure.

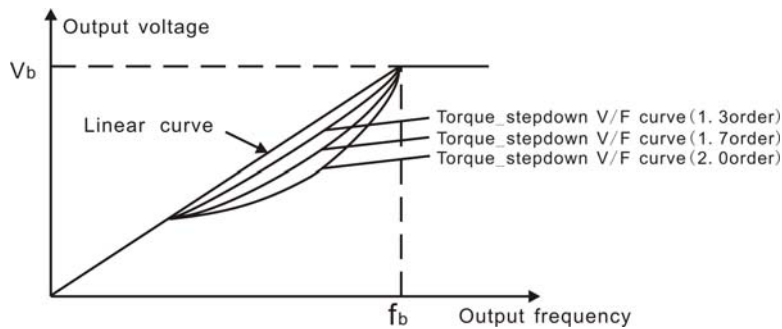

Figure 6.2 Multiple V/F curve diagram.

Function Code	Name	Description	Setting Range	Factory Setting
P0.10	Torque boost	0.0%: (auto) 0.1%~10.0%	0.0~10.0	0.0%

Torque boost will take effect when output frequency is less than cut-off frequency of torque boost (P4.06). Torque boost can improve the torque performance of V/F control at low speed.

The value of torque boost should be determined by the load. The heavier the load, the larger the value.

Notice: This value should not be too large, otherwise the motor would be over-heat or the inverter would be tripped by over-current or over-load.

If P0.10 is set to be 0, the inverter will boost the output torque according to the load automatically. Please refer to following diagram.

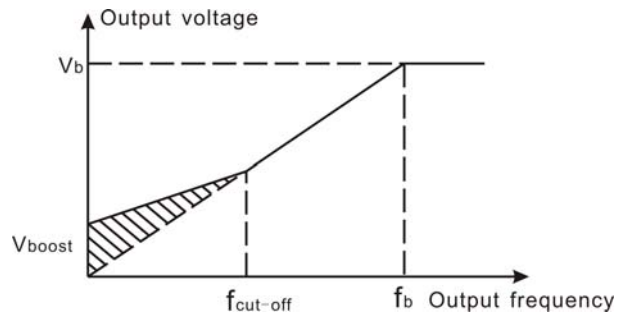

Figure 6.3 Torque boost diagram.

Function Code	Name	Description	Setting Range	Factory Setting
P0.11	Carrier frequency	0.5~15.0kHz	0.5~15.0	Depend on model

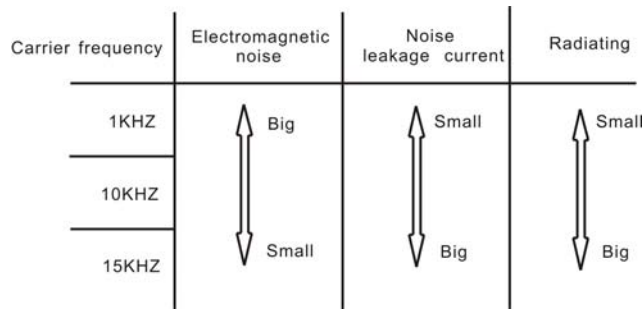

Figure 6.4 Effect of carrier frequency.

The following table is the relationship between power rating and carrier frequency.

Carrier f Model	Highest Carrier f (kHz)	Lowest Carrier f (kHz)	Factory setting (kHz)
G Model: 0.4kW~11kW	15	0.5	8
G Model: 15kW~55kW	8	0.5	4
G Model: 75kW~630kW	6	0.5	2

Carrier frequency will affect the noise of motor and the EMI of inverter.

If the carrier frequency is increased, it will cause better current wave, less harmonic current and lower noise of motor.

Notice:

- **The factory setting is optimal in most cases. Modification of this parameter is not recommended.**
- **If the carrier frequency exceeds the factory setting, the inverter must be derated because the higher carrier frequency will cause more switching loss, higher temperature rise of inverter and stronger electromagnetic interference.**
- **If the carrier frequency is lower than the factory setting, it is possible to cause less output torque of motor and more harmonic current.**

Function Code	Name	Description	Setting Range	Factory Setting
P0.12	Motor parameters autotuning	0: No action 1: Rotation autotuning 2: Static autotuning	0~2	0

Detailed Function Description

0: No action: Forbidding autotuning.

1: Rotation autotuning:

- Do not connect any load to the motor when performing autotuning and ensure the motor is in static status.
- Input the nameplate parameters of motor (P2.00 – P2.04) correctly before performing autotuning. Otherwise the parameters detected by autotuning will be incorrect; it may influence the performance of inverter.
- Set the proper acceleration and deceleration time (P0.07 and P0.08) according to the motor inertia before performing autotuning. Otherwise it may cause over-current and over-voltage fault during autotuning.
- The operation process is as follow:
 - a. Set P0.12 to be 1 then press the **DATA/ENT**, LED will display “-TUN-” and flickers. During “-TUN-” is flickering, press the **PRG/ESC** to exit autotuning.
 - b. Press the **RUN** to start the autotuning, LED will display “TUN-0”.
 - c. After a few seconds the motor will start to run. LED will display “TUN-1” and “RUN/TUNE” light will flicker.
 - d. After a few minutes, LED will display “-END-”. That means the autotuning is finished and return to the stop status.
 - e. During the autotuning, press the **STOP/RST** will stop the autotuning.

Notice: Only keypad can control the autotuning. P0.12 will restore to 0 automatically when the autotuning is finished or cancelled.

2: Static autotuning:

- If it is difficult to disconnect the load, static autotuning is recommended.
- The operation process is the same as rotation autotuning except step c.

Notice: The Mutual inductance and current without load will not be detected by static autotuning, if needed user should input suitable value according to experience.

Function Code	Name	Description	Setting Range	Factory Setting
P0.13	Restore parameters	0: No action 1: Restore factory setting 2: Clear fault records	0~2	0

0: No action

1: Inverter restores all parameters to factory setting except P2 group.

2: Inverter clear all fault records.

This function code will restore to 0 automatically when complete the function operation.

6.2 P1 Group --Start and Stop Control

Function Code	Name	Description	Setting Range	Factory Setting
P1.00	Start Mode	0: Start directly 1: DC braking and start 2: Speed tracking and start	0~2	0

0: Start directly: Start the motor at the starting frequency determined by P1.01.

1: DC braking and start: Inverter will output DC current firstly and then start the motor at the starting frequency. Please refer to description of P1.03 and P1.04. It is suitable for the motor which have small inertia load and may reverse rotation when start.

2: Speed tracking and start: Inverter detects the rotation speed and direction of motor, then start running to its reference frequency based on current speed. This can realize smooth start of rotating motor with big inertia load when instantaneous power off.

Notice: It only applies on the inverter of 7.5kW and above.

Function Code	Name	Description	Setting Range	Factory Setting
P1.01	Starting frequency	0.00~10.00Hz	0.00~10.00	0.00Hz
P1.02	Hold time of starting frequency	0.0~50.0s	0.0~50.0	0.0s

- Set proper starting frequency can increase the starting torque.
- If the reference frequency is less than starting frequency, inverter will be at stand-by status. The indicator of **RUN/TUNE** lights on, inverter has no output.
- The starting frequency could be less than the lower frequency limit (P0.06).
- P1.01 and P1.02 take no effect during FWD/REV switching.

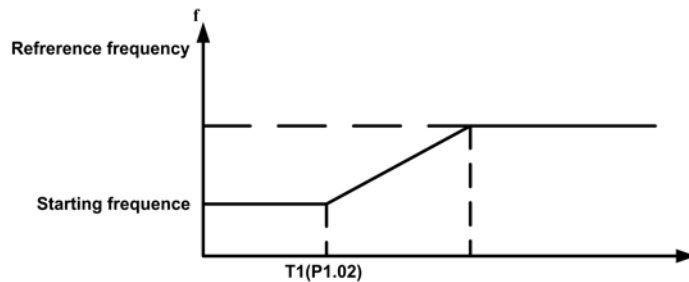

Figure 6.5 Starting diagram.

Detailed Function Description

Function Code	Name	Description	Setting Range	Factory Setting
P1.03	DC Braking current before start	0.0~150.0%	0.0~150.0	0.0%
P1.04	DC Braking time before start	0.0~50.0s	0.0~50.0	0.0s

When inverter starts, it performs DC braking according to P1.03 firstly, then start to accelerate after P1.04.

Notice:

- DC braking will take effect only when P1.00 is set to be 1.
- DC braking is invalid when P1.04 is set to be 0.
- The value of P1.03 is the percentage of rated current of inverter. The bigger the DC braking current, the greater the braking torque.

Function Code	Name	Description	Setting Range	Factory Setting
P1.05	Acceleration / Deceleration mode	0: Linear 1: reserved	0~1	0

0: Linear: Output frequency will increase or decrease with fixed acceleration or deceleration time.

1: Reserved

Notice: CHF inverter offers 4 groups of specific acceleration and deceleration time, which can be determined by the multifunctional ON-OFF input terminals (P5 Group).

Function Code	Name	Description	Setting Range	Factory Setting
P1.06	Stop mode	0: Deceleration to stop 1: Coast to stop	0~1	0

0: Deceleration to stop

When the stop command takes effect, the inverter decreases the output frequency according to P1.05 and the selected acceleration/deceleration time till stop.

1: Coast to stop

When the stop command takes effect, the inverter blocks the output immediately. The motor coasts to stop by its mechanical inertia.

Function Code	Name	Description	Setting Range	Factory Setting
P1.07	Starting frequency of DC braking	0.00~P0.04	0.00~50.00	0.00Hz
P1.08	Waiting time before DC braking	0.0~50.0s	0.0~50.0	0.0s
P1.09	DC braking current	0.0~150.0%	0.0~150.0	0.0%
P1.10	DC braking time	0.0~50.0s	0.0~50.0	0.0s

Starting frequency of DC braking: Start the DC braking when running frequency reaches starting frequency determined by P1.07.

Waiting time before DC braking: Inverter blocks the output before starting the DC braking. After this waiting time, the DC braking will be started. It is used to prevent over-current fault caused by DC braking at high speed.

DC braking current: The value of P1.09 is the percentage of rated current of inverter. The bigger the DC braking current, the greater the braking torque.

DC braking time: The time used to perform DC braking. If the time is 0, the DC braking will be invalid.

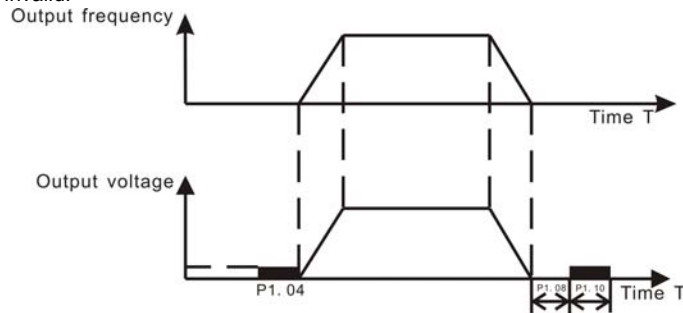

Figure 6.6 DC braking diagram.

Function Code	Name	Description	Setting Range	Factory Setting
P1.11	Dead time of FWD/REV	0.0~3600.0s	0.0~3600.0	0.0s

Set the hold time at zero frequency in the transition between forward and reverse running.

It is shown as following figure:

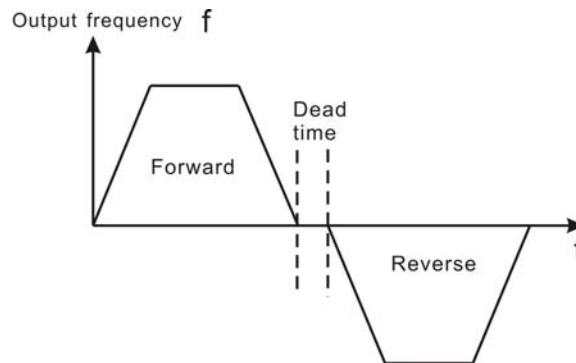

Figure 6.7 FWD/REV dead time diagram.

Detailed Function Description

Function Code	Name	Description	Setting Range	Factory Setting
P1.12	Action when running frequency is less than lower frequency limit	0: Running at the lower frequency limit 1: Stop 2: Stand-by	0~2	0

0: Running at the lower frequency limit (P0.06): The inverter runs at P0.06 when the running frequency is less than P0.06.

1: Stop: This parameter is used to prevent motor running at low speed for a long time.

2: Stand-by: Inverter will stand-by when the running frequency is less than P0.06. When the reference frequency is higher than or equal to P0.06 again, the inverter will start to run automatically.

Function Code	Name	Description	Setting Range	Factory Setting
P1.13	Restart after power off	0: Disabled 1: Enabled	0~1	0
P1.14	Delay time for restart	0.0~3600.0s	0.0~3600.0	0.0s

0: Disabled: Inverter will not automatically restart when power on again until run command takes effect.

1: Enabled: When inverter is running, after power off and power on again, if run command source is key control (P0.03=0) or communication control (P0.03=2), inverter will automatically restart after delay time determined by P1.14; if run command source is terminal control (P0.03=1), inverter will automatically restart after delay time determined by P1.14 only if FWD or REV is active.

Notice:

- If P1.13 is set to be 1, it is recommended that start mode should be set as speed tracing mode (P1.00=2).
- This function may cause the inverter restart automatically, please be cautious.

Function Code	Name	Description	Setting Range	Factory Setting
P1.15	FWD/REV enable option when power on	0: Disabled 1: Enabled	0~1	0

Notice:

- This function only takes effect if run command source is terminal control.
- If P1.15 is set to be 0, when power on, inverter will not start even if FWD/REV terminal is active, until FWD/REV terminal disabled and enabled again.
- If P1.15 is set to be 1, when power on and FWD/REV terminal is active, inverter will start automatically.
- This function may cause the inverter restart automatically, please be cautious.

6.3 P2 Group--Motor Parameters

Function Code	Name	Description	Setting Range	Factory Setting
P2.00	Motor rated power	0.4~900.0kW	0.4~900.0	Depend on model
P2.01	Motor rated frequency	0.01Hz~P0.04	0.01~P0.04	50.00Hz
P2.02	Motor rated speed	0~36000rpm	0~36000	1460rpm
P2.03	Motor rated voltage	0~2000V	0~2000V	Depend on model
P2.04	Motor rated current	0.8~2000.0A	0.8~2000.0	Depend on model

Notice:

- In order to achieve superior performance, please set these parameters according to motor nameplate, then perform autotuning.
- The power rating of inverter should match the motor. If the bias is too big, the control performances of inverter will be deteriorated distinctly.
- Reset P2.00 can initialize P2.05~P2.09 automatically.

Function Code	Name	Description	Setting Range	Factory Setting
P2.05	Motor stator resistance	0.001~65.535Ω	0.001~65.535	Depend on model
P2.06	Motor rotor resistance	0.001~65.535Ω	0.001~65.535	Depend on model
P2.07	Motor leakage inductance	0.1~6553.5mH	0.1~6553.5	Depend on model I
P2.08	Motor mutual inductance	0.1~6553.5mH	0.1~6553.5	Depend on model
P2.09	Current without load	0.01~655.35A	0.01~655.35	Depend on model

After autotuning, the value of P2.05~P2.09 will be automatically updated.

Notice: Do not change these parameters, otherwise it may deteriorate the control performance of inverter.

6.4 P3 Group—Frequency Setting

Function Code	Name	Description	Setting Range	Factory Setting
P3.00	Keypad reference frequency	0.00 Hz ~ P0.04 (Maximum frequency)	0.00~P0.04	50.00Hz

When P3.01 is set to be 0, this parameter is the initial value of inverter reference frequency.

Function Code	Name	Description	Setting Range	Factory Setting
P3.01	Frequency A command source	0: Keypad 1: AI1 2: AI2 3: HDI 4: Simple PLC 5: Multi-Step speed 6: PID 7: Communication	0~7	0

0: Keypad: Please refer to description of P3.00

1: AI1

2: AI2

The reference frequency is set by analog input. CHF series inverter provides 2 analog input terminals. AI1 is 0~10V voltage input terminal, while AI2 is 0~10V voltage input or 0~20mA current input. Voltage input or current input of AI2 can be selected by Jumper J16.

Notice:

- **When AI2 is set as 0~20mA current input, the corresponding voltage range is 0~5V. For detailed relationship between analogue input voltage and frequency, please refer to description of P5.09~P5.13.**
- **100% of AI is corresponding to maximum frequency.**

3: HDI

The reference frequency is set by high speed pulse input. CHF series inverter provides 1 high speed pulse input terminal.

Pulse specification : pulse voltage range 15~30V, and pulse frequency range 0.0~50.0 kHz.

Notice: High speed pulse can only be input through HDI. P5.00 must be set to be 0 (HDI), and P5.19 must be set to be 0 (reference input). For detailed relationship between HDI input and frequency, please refer to description of P5.20~P5.24.

4: Simple PLC

User can set reference frequency, hold time, running direction of each step and acceleration/deceleration time between steps. For details, please refer to description of PA group.

5: Multi-step speed

The reference frequency is determined by PA group. The selection of steps is determined by combination of multi-step speed terminals.

Notice:

- **Multi-step speed mode will enjoy priority in setting reference frequency if P3.01 is not set to be 4 or 5. In this case, only step 1 to step 15 are available.**
- **If P3.01 is set to be 5, step 0 to step 15 can be realized.**
- **Jog has highest priority.**

6: PID

The reference frequency is the result of PID adjustment. For details, please refer to description of P9 group.

7: Communication

The reference frequency is set through RS485. For details, please refer to description of Chapter 10.

Function Code	Name	Description	Setting Range	Factory Setting
P3.02	Frequency B command source	0: AI1 1: AI2 2: HDI	0~2	0
P3.03	Scale of frequency B command	0: Maximum frequency 1: Frequency A command	0~1	0

Frequency B command can act as the independent reference frequency source. Moreover, it can also act as offset of frequency A command.

0: AI1

If P3.03 is set to 0, reference frequency B = AI1 (%) * P0.04 (maximum frequency).

If P3.03 is set to 1, reference frequency B = AI1 (%) * reference frequency A

Notice: AI1 is percentage of range determined by P5.09~P5.13.

1: AI2

The principle is the same as AI1.

Notice: When AI2 is set as 0~20mA current input, the corresponding voltage range is 0~5V.

2: HDI

The principle is the same as AI1.

Function Code	Name	Description	Setting Range	Factory Setting
P3.04	Frequency command selection	0: A 1: B 2: A+B 3: Max (A, B)	0~3	0

Detailed Function Description

This parameter can be used to select the reference frequency command.

0: Only frequency command source A is active.

1: Only Frequency command source B is active.

2: Both Frequency command source A and B are active.

Reference frequency = reference frequency A + reference frequency B.

3: Both Frequency command source A and B are active.

Reference frequency = Max (reference frequency A, reference frequency B).

Notice: The frequency command source can be selected not only P3.04 but also by multifunctional terminals. Please refer to description of P5 Group.

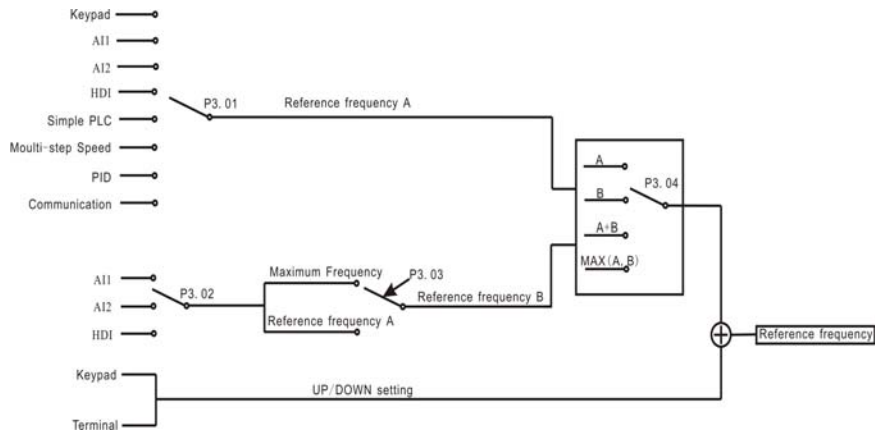

Figure 6.8 Reference frequency diagram.

Function Code	Name	Description	Setting Range	Factory Setting
P3.05	UP/DOWN setting	0: Valid, save UP/DOWN value when power off 1: Valid, do not save UP/DOWN value when power off 2: Invalid 3: Valid during running, clear when stop.	0~3	0

0: Valid, save UP/DOWN value when power off.

User can adjust the reference frequency by UP/DOWN. The value of UP/DOWN can be saved when power off.

1: Valid, do not save UP/DOWN value when power off.

User can adjust the reference frequency by UP/DOWN, but the value of UP/DOWN will not be saved when power off.

2: Invalid.

User can not adjust the reference frequency by UP/DOWN. The value of UP/DOWN will be cleared if P3.05 is set to 2.

3: Valid during running, clear when stop.

User can only adjust the reference frequency by UP/DOWN during the inverter is running. The value of UP/DOWN will be cleared when the inverter stops.

Notice:

- **UP/DOWN function can be achieved by keypad (▲) and (▼) and multifunctional terminals.**
- **Reference frequency can be adjusted by UP/DOWN.**
- **UP/DOWN has highest priority which means UP/DOWN is always active no matter which frequency command source is.**
- **When the factory setting is restored (P0.13 is set to be 1), the value of UP/DOWN will be cleared.**

Function Code	Name	Description	Setting Range	Factory Setting
P3.06	Jog reference	0.00~P0.04	0.00~ P0.04	5.00Hz
P3.07	Jog acceleration time	0.1~3600.0s	0.1~3600.0	Depend on model
P3.08	Jog deceleration time	0.1~3600.0s	0.1~3600.0	Depend on model

The meaning and factory setting of P3.07 and P3.08 is the same as P0.07 and P0.08. No matter what the value of P1.00 and P1.06 are, jog will start as start directly mode and stop as deceleration to stop mode.

Function Code	Name	Description	Setting Range	Factory Setting
P3.09	Skip frequency 1	0.00~P0.04	0.00~P0.04	0.00Hz
P3.10	Skip frequency 2	0.00~P0.04	0.00~P0.04	0.00Hz
P3.11	Skip frequency bandwidth	0.00~P0.04	0.00~P0.04	0.00Hz

By means of setting skip frequency, the inverter can keep away from the mechanical resonance with the load. P3.09 and P3.10 are centre value of frequency to be skipped.

Notice:

- **If P3.11 is 0, the skip function is invalid.**
- **If both P3.09 and P3.10 are 0, the skip function is invalid no matter what P3.11 is.**
- **Operation is prohibited within the skip frequency bandwidth, but changes during acceleration and deceleration are smooth without skip.**

The relation between output frequency and reference frequency is shown in following figure.

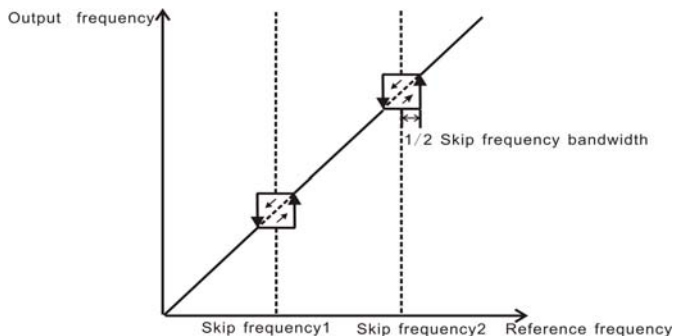

Figure 6.9 Skip frequency diagram.

6.5 P4 Group—V/F Control

Function Code	Name	Description	Setting Range	Factory Setting
P4.00	Running direction selection	0: Forward 1: Reverse 2: Forbid reverse	0~2	0

Notice:

- The rotation direction of motor is corresponding to the wiring of motor.
- When the factory setting is restored (P0.13 is set to be 1), the rotation direction of motor may be changed. Please be cautious to use.
- If P4.00 is set to 2, user can not change rotation direction of motor by **QUICK/JOG** or terminal.

Function Code	Name	Description	Setting Range	Factory Setting
P4.01	PWM mode	0: Fixed 1: Random	0~1	0

0: Fixed: The noise frequency of motor is fixed.

1: Random: This mode can restrain the noise of motor effectively, but may increase the harmonic of motor.

Function Code	Name	Description	Setting Range	Factory Setting
P4.02	Carrier frequency adjust based on temperature	0: Disabled 1: Enabled	0~1	0

0: Disabled: Carrier frequency is fixed.

1: Enabled: Carrier frequency will be adjusted based on internal temperature of the inverter. The higher the temperature, the lower the carrier frequency.

Function Code	Name	Description	Setting Range	Factory Setting
P4.03	AVR function	0: Disabled 1: Enabled all the time 2: Disabled during deceleration	0~2	1

AVR (Auto Voltage Regulation) function ensure the output voltage of inverter stable no matter how the DC bus voltage changes. During deceleration, if AVR function is disabled, the deceleration time will be short but the current will be big. If AVR function is enabled all the time, the deceleration time will be long but the current will be small.

Function Code	Name	Description	Setting Range	Factory Setting
P4.04	Slip compensation limit	0.00~200.0%	0.00~200.00	0.0%

The slip compensation function calculates the torque of motor according to the output current and compensates for output frequency. This function is used to improve speed accuracy when operating with a load. P4.04 sets the slip compensation limit as a percentage of motor rated slip, with the motor rated slip taken as 100%.

Function Code	Name	Description	Setting Range	Factory Setting
P4.05	Auto energy saving selection	0: Disabled 1: Enabled	0~1	0

When P4.05 is set to be 1, while there is a light load such as pumps or fans, it will reduce the inverter output voltage and saves energy.

Function Code	Name	Description	Setting Range	Factory Setting
P4.06	Torque boost cut-off	0.0%~50.0% (motor rated frequency)	0.0~50.0	20.0%

Please refer to the description of P0.10.

Function Code	Name	Description	Setting Range	Factory Setting
P4.07	V/F frequency 1	0.00Hz~ P4.09	0.00~P4.09	5.00Hz
P4.08	V/F voltage 1	0.0%~100.0%	0.0~100.0	10.0%
P4.09	V/F frequency 2	P4.07~ P4.11	P4.07~ P4.11	30.00Hz
P4.10	V/F voltage 2	0.0%~100.0%	0.0~100.0	60.0%
P4.11	V/F frequency 3	P4.09~ P2.01	P4.09~ P2.01	50.00Hz
P4.12	V/F voltage 3	0.0%~100.0%	0.0~100.0	100.0%

Detailed Function Description

This function is only active when P0.09 is set to be 1. P4.07~P4.12 are used to set the user-defined V/F curve. The value should be set according to the load characteristic of motor.

Notice:

- $0 < V1 < V2 < V3 < \text{rated voltage}$.
- $0 < f1 < f2 < f3 < \text{rated frequency}$.
- The voltage corresponding to low frequency should not be set too high, otherwise it may cause motor overheat or inverter fault

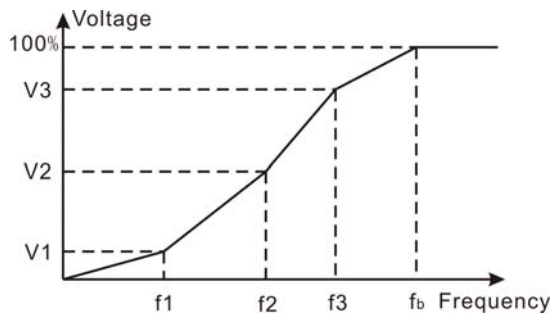

Figure 6.10 V/F curve setting diagram.

6.6 P5 Group--Input Terminals

Function Code	Name	Description	Setting Range	Factory Setting
P5.00	HDI selection	0: High speed pulse input 1: ON-OFF input	0~1	0

Please refer to description of HDI in P3.01.

Function Code	Name	Description	Setting Range	Factory Setting
P5.01	S1 terminal function	Programmable multifunctional terminal	0~39	1
P5.02	S2 terminal function	Programmable multifunctional terminal	0~39	4
P5.03	S3 terminal function	Programmable multifunctional terminal	0~39	7
P5.04	S4 terminal function	Programmable multifunctional terminal	0~39	0
P5.05	HDI terminal function	Programmable multifunctional terminal	0~39	0

Notice: P5.05 is only used when P5.00 is set to be 1.

The meaning of each setting is shown in following table.

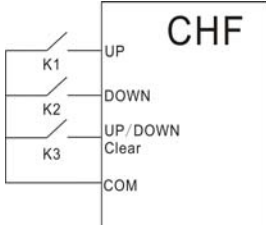
Setting value	Function	Description																									
0	Invalid	Please set unused terminals to be invalid to avoid malfunction.																									
1	Forward	Please refer to description of P5.07.																									
2	Reverse																										
3	3-wire control																										
4	Jog forward	Please refer to description of P3.06~P3.08.																									
5	Jog reverse																										
6	Coast to stop	The inverter blocks the output immediately. The motor coasts to stop by its mechanical inertia.																									
7	Reset fault	Resets faults that have occurred. It has the same function as STOP/RST .																									
8	Pause running	When this terminal takes effect, inverter decelerates to stop and save current status, such as PLC, traverse frequency and PID. When this terminal takes no effect, inverter restores the status before pause.																									
9	External fault input	Stop the inverter and output a alarm when a fault occurs in a peripheral device.																									
10	Up command	<p>The reference frequency of inverter can be adjusted by UP command and DOWN command.</p> 																									
11	DOWN command																										
12	Clear UP/DOWN		Use this terminal to clear UP/DOWN setting. Please refer to description of P3.05.																								
13	Switch between A and B	<table border="1"> <thead> <tr> <th colspan="2" style="text-align: center;">P3.04</th> <th>A</th> <th>B</th> <th>A+B</th> </tr> </thead> <tbody> <tr> <td colspan="2" style="text-align: center;">Terminal action</td> <td>B</td> <td>A</td> <td style="text-align: center;">/</td> </tr> <tr> <td colspan="2" style="text-align: center;">13 valid</td> <td>A+B</td> <td style="text-align: center;">/</td> <td>A</td> </tr> <tr> <td colspan="2" style="text-align: center;">14 valid</td> <td style="text-align: center;">/</td> <td>A+B</td> <td>B</td> </tr> <tr> <td colspan="2" style="text-align: center;">15 valid</td> <td style="text-align: center;">/</td> <td style="text-align: center;">/</td> <td style="text-align: center;">/</td> </tr> </tbody> </table>	P3.04		A	B	A+B	Terminal action		B	A	/	13 valid		A+B	/	A	14 valid		/	A+B	B	15 valid		/	/	/
P3.04			A	B	A+B																						
Terminal action			B	A	/																						
13 valid		A+B	/	A																							
14 valid		/	A+B	B																							
15 valid		/	/	/																							
14	Switch between A and A+B																										
15	Switch between B and A+B																										

Detailed Function Description

16	Multi-step speed reference 1	<p>16 steps speed control can be realized by the combination of these four terminals. For details, please refer to: Multi-step speed reference terminal status and according step value table:</p> <p>Notice: multi-speed 1 is low bit, and multi-speed 4 is high bit.</p> <table border="1"> <thead> <tr> <th>Multi-speed terminal 4</th> <th>Multi-speed terminal 3</th> <th>Multi-speed terminal 2</th> <th>Multi-speed terminal 1</th> </tr> </thead> <tbody> <tr> <td>BIT3</td> <td>BIT2</td> <td>BIT1</td> <td>BIT0</td> </tr> </tbody> </table>	Multi-speed terminal 4	Multi-speed terminal 3	Multi-speed terminal 2	Multi-speed terminal 1	BIT3	BIT2	BIT1	BIT0							
Multi-speed terminal 4	Multi-speed terminal 3		Multi-speed terminal 2	Multi-speed terminal 1													
BIT3	BIT2		BIT1	BIT0													
17	Multi-step speed reference 2																
18	Multi-step speed reference 3																
19	Multi-step speed reference 4																
20	Multi-step speed pause	Keep current step unchanged no matter what the input status of four multi-step speed terminals is.															
21	ACC/DEC time selection 1	<p>4 groups of ACC/DEC time can be selected by the combination of these two terminals.</p> <table border="1"> <thead> <tr> <th>ACC/DEC time selection 2</th> <th>ACC/DEC time selection 1</th> <th>ACC/DEC time</th> </tr> </thead> <tbody> <tr> <td>OFF</td> <td>OFF</td> <td>ACC/DEC time 0 (P0.07、P0.08)</td> </tr> <tr> <td>OFF</td> <td>ON</td> <td>ACC/DEC time 1 (P8.00、P8.01)</td> </tr> <tr> <td>ON</td> <td>OFF</td> <td>ACC/DEC time 2 (P8.02、P8.03)</td> </tr> <tr> <td>ON</td> <td>ON</td> <td>ACC/DEC time 3 (P8.04、P8.05)</td> </tr> </tbody> </table>	ACC/DEC time selection 2	ACC/DEC time selection 1	ACC/DEC time	OFF	OFF	ACC/DEC time 0 (P0.07、P0.08)	OFF	ON	ACC/DEC time 1 (P8.00、P8.01)	ON	OFF	ACC/DEC time 2 (P8.02、P8.03)	ON	ON	ACC/DEC time 3 (P8.04、P8.05)
ACC/DEC time selection 2	ACC/DEC time selection 1	ACC/DEC time															
OFF	OFF	ACC/DEC time 0 (P0.07、P0.08)															
OFF	ON	ACC/DEC time 1 (P8.00、P8.01)															
ON	OFF	ACC/DEC time 2 (P8.02、P8.03)															
ON	ON	ACC/DEC time 3 (P8.04、P8.05)															
22	ACC/DEC time selection 2																
23	Reset simple PLC when stop	When simple PLC stops, the status of PLC such as running step, running time and running frequency will be cleared when this terminal is enabled.															
24	Pause simple PLC	Inverter runs at zero frequency and PLC pauses the timing when this terminal is enabled. If this terminal is disabled, inverter will start and continue the PLC operation from the status before pause.															
25	Pause PID	PID adjustment will be paused and inverter keeps output frequency unchanged.															
26	Pause traverse operation	Inverter keeps output frequency unchanged. If this terminal is disabled, inverter will continue traverse operation from current frequency.															

27	Reset traverse operation	Reference frequency of inverter will be forced as center frequency of traverse operation.
28	Reset counter	Clear the value of counter.
29	Reset length	Clear the value of actual length (P8.13).
30	ACC/DEC ramp hold	Pauses acceleration or deceleration and maintains output frequency. When this terminal is disabled, acceleration/deceleration is restarted.
31	Counter input	The pulse input terminal of internal counter. Maximum pulse frequency: 200Hz.
32	UP/DOWN invalid temporarily	UP/DOWN setting is invalid and will not be cleared. When this terminal is disabled, UP/DOWN setting before will be valid again.
33~39	Reserved	Reserved

Multi-step speed reference terminal status and according step value table:

Terminal Step	Multi-step speed reference1	Multi-step speed reference2	Multi-step speed reference3	Multi-step speed reference4
0	OFF	OFF	OFF	OFF
1	ON	OFF	OFF	OFF
2	OFF	ON	OFF	OFF
3	ON	ON	OFF	OFF
4	OFF	OFF	ON	OFF
5	ON	OFF	ON	OFF
6	OFF	ON	ON	OFF
7	ON	ON	ON	OFF
8	OFF	OFF	OFF	ON
9	ON	OFF	OFF	ON
10	OFF	ON	OFF	ON
11	ON	ON	OFF	ON
12	OFF	OFF	ON	ON
13	ON	OFF	ON	ON
14	OFF	ON	ON	ON
15	ON	ON	ON	ON

Detailed Function Description

Function Code	Name	Description	Setting Range	Factory Setting
P5.06	ON-OFF filter times	1~10	1~10	5

This parameter is used to set filter strength of terminals (S1~S4, HDI). When interference is heavy, user should increase this value to prevent malfunction.

Function Code	Name	Description	Setting Range	Factory Setting
P5.07	FWD/REV control mode	0: 2-wire control mode 1 1: 2-wire control mode 2 2: 3-wire control mode 1 3: 3-wire control mode 2	0~3	0

This parameter defines four different control modes that control the inverter operation through external terminals.

0: 2-wire control mode 1: Integrate START/STOP command with run direction.

K1	K2	Run command
OFF	OFF	Stop
ON	OFF	FWD
OFF	ON	REV
ON	ON	Stop

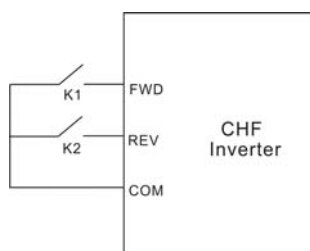

Figure 6.11 2-wire control mode 1.

1: 2-wire control mode 2: START/STOP command is determined by FWD terminal. Run direction is determined by REV terminal.

K1	K2	Run command
OFF	OFF	Stop
ON	OFF	FWD
OFF	ON	Stop
ON	ON	REV

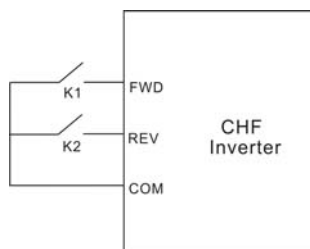

Figure 6.12 2-wire control mode 2.

2: 3-wire control mode 1:

SB1: Start button

SB2: Stop button (NC)

K: Run direction button

Terminal SIn is the multifunctional input terminal of S1~S4 and HDI. The terminal function should be set to be 3 (3-wire control).

K	Run command
OFF	FWD
ON	REV

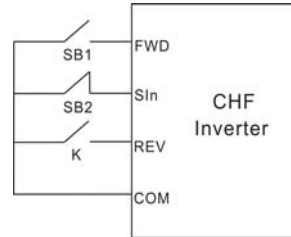

Figure 6.13 3-wire control mode 1.

3: 3-wire control mode 2:

SB1: Forward run button

SB2: Stop button (NC)

SB3: Reverse run button

Terminal SIn is the multifunctional input terminal of S1~S4 and HDI. The terminal function should be set to be 3 (3-wire control).

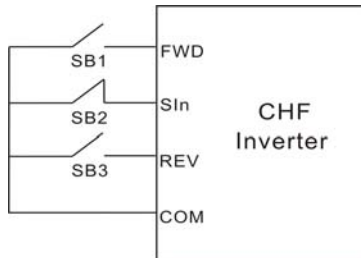

Figure 6.14 3-wire control mode 2.

Notice: When 2-wire control mode is active, the inverter will not run in following situation even if FWD/REV terminal is enabled:

- Coast to stop (press **RUN** and **STOP/RST** at the same time).
- Stop command from serial communication.
- FWD/REV terminal is enabled before power on. Please refer to description of P1.15.

Detailed Function Description

Function Code	Name	Description	Setting Range	Factory Setting
P5.08	UP/DOWN setting change rate	0.01~50.00Hz/s	0.01~50.00	0.50Hz/s

This parameter is used to determine how fast UP/DOWN setting changes.

Function Code	Name	Description	Setting Range	Factory Setting
P5.09	AI1 lower limit	0.00V~10.00V	0.00~10.00	0.00V
P5.10	AI1 lower limit corresponding setting	-100.0%~100.0%	-100.0~100.0	0.0%
P5.11	AI1 upper limit	0.00V~10.00V	0.00~10.00	10.00V
P5.12	AI1 upper limit corresponding setting	-100.0%~100.0%	-100.0~100.0	100.0%
P5.13	AI1 filter time constant	0.00s~10.00s	0.00~10.00	0.10s

These parameters determine the relationship between analog input voltage and the corresponding setting value. When the analog input voltage exceeds the range between lower limit and upper limit, it will be regarded as the upper limit or lower limit.

The analog input AI1 can only provide voltage input, and the range is 0V~10V.

For different applications, the corresponding value of 100.0% analog setting is different.

For details, please refer to description of each application.

Notice: AI1 lower limit must be less or equal to AI1 upper limit.

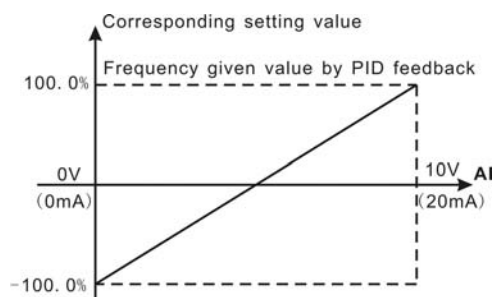

Figure 6.15 Relationship between AI and corresponding setting.

AI1 filter time constant is effective when there are sudden changes or noise in the analog input signal. Responsiveness decreases as the setting increases.

Function Code	Name	Description	Setting Range	Factory Setting
P5.14	AI2 lower limit	0.00V~10.00V	0.00~10.00	0.00V
P5.15	AI2 lower limit corresponding setting	-100.0%~100.0%	-100.0~100.0	0.0%
P5.16	AI2 upper limit	0.00V~10.00V	0.00~10.00	10.00V
P5.17	AI2 upper limit corresponding setting	-100.0%~100.0%	-100.0~100.0	100.0%
P5.18	AI2 filter time constant	0.00s~10.00s	0.00~10.00	0.10s

Please refer to description of AI1. When AI2 is set as 0~20mA current input, the corresponding voltage range is 0~5V.

Function Code	Name	Description	Setting Range	Factory Setting
P5.19	HDI function selection	0: Reference input 1: Length input 2: High-speed count input	0~2	0

0: Reference input, such as frequency, PID setting and PID feedback.

1: Length input: the input of length pulse.

2: High-speed count input: If the count pulse frequency is too high to use S1~S4, it is necessary to use HDI.

Notice: When P5.19 is set to be 0, P5.20~P5.24 will take effective.

Function Code	Name	Description	Setting Range	Factory Setting
P5.20	HDI lower limit	0.0 kHz ~50.0kHz	0.0~50.0	0.0kHz
P5.21	HDI lower limit corresponding setting	-100.0%~100.0%	-100.0~100.0	0.0%
P5.22	HDI upper limit	0.0 kHz ~50.0kHz	0.0~50.0	50.0kHz
P5.23	HDI upper limit corresponding setting	-100.0%~100.0%	-100.0~100.0	100.0%
P5.24	HDI filter time constant	0.00s~10.00s	0.00~10.00	0.10s

The description of P5.20~P5.24 is similar to AI1.

6.7 P6 Group--Output Terminals

Function Code	Name	Description	Setting Range	Factory Setting
P6.00	HDO selection	0: High-speed pulse output 1: ON-OFF output	0~1	0

0: High-speed pulse output: The maximum pulse frequency is 50.0 kHz. Please refer to description of P6.09.

1: ON-OFF output: Please refer to description of P6.01.

Notice: The output of HDO terminal is OC (open collector) output.

Function Code	Name	Description	Setting Range	Factory Setting
P6.01	HDO ON-OFF output selection	Open-collector output	0~25	1
P6.02	Relay 1 output selection	Relay output	0~25	4
P6.03	Relay 2 output selection (4.0kW and above)	Relay output	0~25	0

OC/Relay output functions are indicated in the following table:

Setting Value	Function	Description
0	No output	Output terminal has no function.
1	Running	ON: Run command is ON or voltage is being output.
2	Run forward	ON: During forward run.
3	Run reverse	ON: During reverse run.
4	Fault output	ON: Inverter is in fault status.
5	FDT reached	Please refer to description of P8.21, P8.22.
6	Frequency reached	Please refer to description of P8.23.
7	Zero speed running	ON: The running frequency of inverter is zero.
8	Preset count value reached	Please refer to description of P8.18.
9	Specified count value reached	Please refer to description of P8.19.
10	Length reached	ON: Actual length (P8.13) reach the value of P8.12.
11	Simple PLC step completed	After simple PLC completes one step, inverter will output ON signal for 500ms.
12	PLC cycle completed	After simple PLC completes one cycle, inverter will output ON signal for 500ms.
13	Running time	ON: The accumulated running time of inverter reaches

Detailed Function Description

	reached	the value of P8.20.
14	Upper frequency limit reached	ON: Running frequency reaches the value of P0.05.
15	Lower frequency limit reached	ON: Running frequency reaches the value of P0.06.
16	Ready	ON: Inverter is ready (no fault, power is ON).
17	Auxiliary motor 1 started	In the case of simple water supply system with one inverter driving three pumps, it is used to control auxiliary pumps. For details, please refer to descriptions of P8.25, P8.26 and P8.27.
18	Auxiliary motor 2 started	
21~25	Reserved	Reserved

Function Code	Name	Description	Setting Range	Factory Setting
P6.04	AO function selection	Multifunctional analog output	0~12	0
P6.05	HDO function selection	Multifunctional high-speed pulse output	0~12	0

AO/HDO output functions are indicated in the following table:

Setting Value	Function	Range
0	Running frequency	0~maximum frequency (P0.04)
1	Reference frequency	0~ maximum frequency (P0.04)
2	Motor speed	0~2* rated synchronous speed of motor
3	Output current	0~2* inverter rated current
4	Output voltage	0~1.5* inverter rated voltage
5	Output power	0~2* rated power
6	Output torque	0~2*rated current
7	AI1 voltage	0~10V
8	AI2 voltage/current	0~10V/0~20mA
9	HDI frequency	0.1~50.0kHz
10	Length value	0~presetting length (P8.12)
11	Count value	0~presetting count value (P8.18)
12	Reserved	Reserved

Detailed Function Description

Function Code	Name	Description	Setting Range	Factory Setting
P6.06	AO lower limit	0.0%~100.0%	0.0~100.0	0.0%
P6.07	AO lower limit corresponding output	0.00V ~10.00V	0.00~10.00	0.00V
P6.08	AO upper limit	0.0%~100.0%	0.0~100.0	100.0%
P6.09	AO upper limit corresponding output	0.00V ~10.00V	0.00~10.00	10.00V

These parameters determine the relationship between analog output voltage/current and the corresponding output value. When the analog output value exceeds the range between lower limit and upper limit, it will output the upper limit or lower limit.

When AO is current output, 1mA is corresponding to 0.5V.

For different applications, the corresponding value of 100.0% analog output is different.

For details, please refer to description of each application.

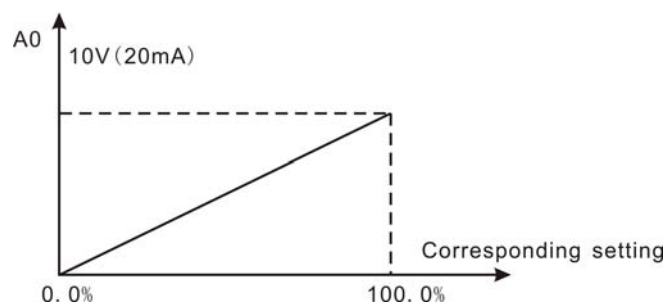

Figure 6.16 Relationship between AO and corresponding setting.

Function Code	Name	Description	Setting Range	Factory Setting
P6.10	HDO lower limit	0.0%~100.0%	0.0~100.0	0.0%
P6.11	HDO lower limit corresponding output	0.0 ~ 50.0kHz	0.0~50.0	0.0kHz
P6.12	HDO upper limit	0.0%~100.0%	0.0~100.0	100.0%
P6.13	HDO upper limit corresponding output	0.0 ~ 50.0kHz	0.0~50.0	50.0kHz

The description of P6.10~P6.13 is similar to AO.

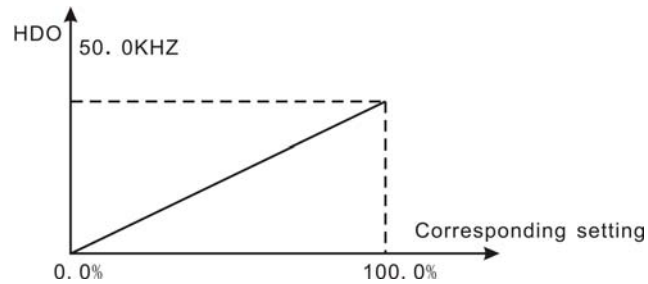

Figure 6.17 Relationship between HDO and corresponding setting.

6.8 P7 Group—Display Interface

Function Code	Name	Description	Setting Range	Factory Setting
P7.00	User password	0~65535	0~65535	0

The password protection function will be valid when set to be any nonzero data. When P7.00 is set to be 00000, user's password set before will be cleared and the password protection function will be disabled.

After the password has been set and becomes valid, the user can not access menu if the user's password is not correct. Only when a correct user's password is input, the user can see and modify the parameters. Please keep user's password in mind.

Function Code	Name	Description	Setting Range	Factory Setting
P7.01	LCD language selection	Not available	0~1	0
P7.02	Parameter copy	Not available	0~2	0
P7.03	QUICK/JOG function selection	0: Jog 1: FDW/REV switching 2: Clear UP/DOWN setting 3: Quick debugging mode 1 4: Quick debugging mode 2 5: Quick debugging mode 3	0~5	0

QUICK/JOG is a multifunctional key, whose function can be defined by the value of

Detailed Function Description

P7.03.

0: Jog: Press **QUICK/JOG**, the inverter will jog.

1: FWD/REV switching: Press **QUICK/JOG**, the running direction of inverter will reverse.
It is only valid if P0.03 is set to be 0.

2: Clear UP/DOWN setting: Press **QUICK/JOG**, the UP/DOWN setting will be cleared.

3~5: Quick debugging mode 1, 2, 3: Please refer to description of 5.4.2.

Function Code	Name	Description	Setting Range	Factory Setting
P7.04	STOP/RST function selection	0: Valid when keypad control (P0.03=0) 1: Valid when keypad or terminal control (P0.03=0 or 1) 2: Valid when keypad or communication control (P0.03=0 or 2) 3: Always valid	0~3	0

Notice:

- The value of P7.04 only determines the STOP function of **STOP/RST**.
- The RESET function of **STOP/RST** is always valid.

Function Code	Name	Description	Setting Range	Factory Setting
P7.05	Keypad display selection	0: Preferential to external keypad 1: Both display, only external key valid. 2: Both display, only local key valid. 3: Both display and key valid.	0~3	0

0: When external keypad exists, local keypad will be invalid.

1: Local and external keypad display simultaneously, only the key of external keypad is valid.

2: Local and external keypad display simultaneously, only the key of local keypad is valid.

3: Local and external keypad display simultaneously, both keys of local and external keypad are valid.

Notice: This function should be used cautiously, otherwise it may cause malfunction.

Function Code	Name	Description	Setting Range	Factory Setting
P7.06	Running status display selection 1	0~0xFFFF	0~0xFFFF	0x07FF
P7.07	Running status display selection 2	0~0xFFFF	0~0xFFFF	0x0000

P7.06 and P7.07 define the parameters that can be displayed by LED in running status. If Bit is 0, the parameter will not be displayed; If Bit is 1, the parameter will be displayed.

Press **» /SHIFT** to scroll through these parameters in right order. Press **DATA/ENT** + **QUICK/JOG** to scroll through these parameters in left order.

The display content corresponding to each bit of P7.06 is described in the following table:

BIT7	BIT6	BIT5	BIT4	BIT3	BIT2	BIT1	BIT0
Output power	Line speed	Rotation speed	Output current	Output voltage	DC bus voltage	Reference frequency	Output frequency
BIT15	BIT14	BIT13	BIT12	BIT11	BIT10	BIT9	BIT8
Step No. of PLC or multi-step	Count value	Length value	Output terminal status	Input terminal status	PID feedback	PID preset	Output torque

For example, if user wants to display output voltage, DC bus voltage, Reference frequency, Output frequency, Output terminal status, the value of each bit is as the following table:

BIT7	BIT6	BIT5	BIT4	BIT3	BIT2	BIT1	BIT0
0	0	0	0	1	1	1	1
BIT15	BIT14	BIT13	BIT12	BIT11	BIT10	BIT9	BIT8
0	0	0	1	0	0	0	0

The value of P7.06 is 100Fh.

Notice: I/O terminal status is displayed in decimal. For details, please refer to description of P7.21 and P7.22.

The display content corresponding to each bit of P7.07 is described in the following table:

Detailed Function Description

BIT7	BIT6	BIT5	BIT4	BIT3	BIT2	BIT1	BIT0
Reserved	Reserved	Accumulated running time	Load percentage of inverter	Load percentage of motor	HDI frequency	AI2	AI1
BIT15	BIT14	BIT13	BIT12	BIT11	BIT10	BIT9	BIT8
Reserved	Reserved	Reserved	Reserved	Reserved	Reserved	Reserved	Reserved

Function Code	Name	Description	Setting Range	Factory Setting
P7.08	Stop status display selection	0~0xFFFF	0~0xFFFF	0x00FF

P7.08 determines the display parameters in stop status. The setting method is similar with P7.06.

The display content corresponding to each bit of P7.08 is described in the following table:

BIT7	BIT6	BIT5	BIT4	BIT3	BIT2	BIT1	BIT0
AI2	AI1	PID feedback	PID preset	Output terminal status	Input terminal status	DC bus voltage	Reference frequency
BIT15	BIT14	BIT13	BIT12	BIT11	BIT10	BIT9	BIT8
Reserved	Reserved	Reserved	Reserved	Reserved	Reserved	Step No. of PLC or multi-step	HDI frequency

Function Code	Name	Description	Setting Range	Default Value
P7.09	Coefficient of rotation speed	0.1~999.9%	0.1~999.9%	100.0%

This parameter is used to calibrate the bias between actual mechanical speed and rotation speed. The formula is as below:

Actual mechanical speed = 120 * output frequency * P7.09 / Number of poles of motor

Function Code	Name	Description	Setting Range	Default Value
P7.10	Coefficient of line speed	0.1~999.9%	0.1~999.9%	1.0%

This parameter is used to calculate the line speed based on actual mechanical speed.

The formula is as below:

Line speed = actual mechanical speed * P7.10

Function Code	Name	Description	Setting Range	Factory Setting
P7.11	Rectify module temperature	0~100.0℃		
P7.12	IGBT module temperature	0~100.0℃		
P7.13	Software version			
P7.14	Accumulated running time	0~65535h		

Rectify module temperature: Indicates the temperature of rectify module. Overheat protection point of different inverter may be different.

IGBT module temperature: Indicates the temperature of IGBT module. Overheat protection point of different inverter may be different.

Software version: Indicates current software version of DSP.

Accumulated running time: Displays accumulated running time of inverter.

Notice: Above parameters are read only.

Function Code	Name	Description	Setting Range	Factory Setting
P7.15	Third latest fault type	0~24		
P7.16	Second latest fault type	0~24		
P7.17	Latest fault type	0~24		

These parameters record three recent fault types. For details, please refer to description of chapter 7.

Function Code	Name	Description	Setting Range	Factory Setting
P7.18	Output frequency at current fault	Output frequency at current fault.		
P7.19	Output current at current fault	Output current at current fault.		
P7.20	DC bus voltage at current fault	DC bus voltage at current fault.		

Detailed Function Description

P7.21	Input terminal status at current fault	<p>This value records ON-OFF input terminal status at current fault. The meaning of each bit is as below:</p> <table border="1"> <tr> <td>BIT4</td> <td>BIT3</td> <td>BIT2</td> <td>BIT1</td> <td>BIT0</td> </tr> <tr> <td>HDI</td> <td>S4</td> <td>S3</td> <td>S2</td> <td>S1</td> </tr> </table> <p>1 indicates corresponding input terminal is ON, while 0 indicates OFF. Notice: This value is displayed as decimal.</p>	BIT4	BIT3	BIT2	BIT1	BIT0	HDI	S4	S3	S2	S1		
BIT4	BIT3	BIT2	BIT1	BIT0										
HDI	S4	S3	S2	S1										
P7.22	Output terminal status at current fault	<p>This value records output terminal status at current fault. The meaning of each bit is as below:</p> <table border="1"> <tr> <td>BIT3</td> <td>BIT2</td> <td>BIT1</td> <td>BIT0</td> </tr> <tr> <td>R02</td> <td>R01</td> <td>HDO</td> <td></td> </tr> </table> <p>1 indicates corresponding output terminal is ON, while 0 indicates OFF. Notice: This value is displayed as decimal.</p>	BIT3	BIT2	BIT1	BIT0	R02	R01	HDO					
BIT3	BIT2	BIT1	BIT0											
R02	R01	HDO												

6.9 P8 Group--Enhanced Function

Function Code	Name	Description	Setting Range	Factory Setting
P8.00	Acceleration time 1	0.1~3600.0s	0.1~3600.0	Depend on model
P8.01	Deceleration time 1	0.1~3600.0s	0.1~3600.0	Depend on model
P8.02	Acceleration time 2	0.1~3600.0s	0.1~3600.0	Depend on model
P8.03	Deceleration time 2	0.1~3600.0s	0.1~3600.0	Depend on model
P8.04	Acceleration time 3	0.1~3600.0s	0.1~3600.0	Depend on model
P8.05	Deceleration time 3	0.1~3600.0s	0.1~3600.0	Depend on model

For details, please refer to description of P0.07 and P0.08.

Function Code	Name	Description	Setting Range	Factory Setting
P8.06	Traverse amplitude	0.0~100.0%	0.0~100.0	0.0%
P8.07	Jitter frequency	0.0~50.0%	0.0~50.0	0.0%
P8.08	Rise time of traverse	0.1~3600.0s	0.1~3600.0	5.0s
P8.09	Fall time of traverse	0.1~3600.0s	0.1~3600.0	5.0s

Traverse operation is widely used in textile and chemical fiber industry. The typical application is shown in following figure.

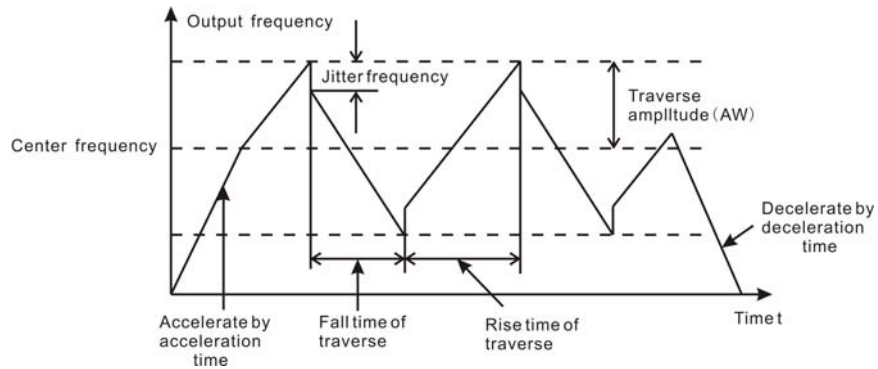

Figure 6.18 Traverse operation diagram.

Center frequency (CF) is reference frequency.

Traverse amplitude (AW) = center frequency (CF) * P8.06%

Jitter frequency = traverse amplitude (AW) * P8.07%

Rise time of traverse: Indicates the time rising from the lowest traverse frequency to the highest traverse frequency.

Fall time of traverse: Indicates the time falling from the highest traverse frequency to the lowest traverse frequency.

Notice:

- **P8.06 determines the output frequency range which is as below:**
 $(1-P8.06\%) * \text{reference frequency} \leq \text{output frequency} \leq (1+P8.06\%) * \text{reference frequency}$
- **The output frequency of traverse is limited by upper frequency limit (P0.05) and lower frequency limit (P0.06).**

Function Code	Name	Description	Setting Range	Factory Setting
P8.10	Auto reset times	0~3	0~3	0
P8.11	Reset interval	0.1~100.0s	0.1~100.0	1.0s

Auto reset function can reset the fault in preset times and interval. When P8.10 is set to be 0, it means "auto reset" is disabled and the protective device will be activated in case of fault.

Notice: The fault such as OUT 1, OUT 2, OUT 3, OH1 and OH2 cannot be reset automatically.

Detailed Function Description

Function Code	Name	Description	Setting Range	Factory Setting
P8.12	Preset length	0~65535m	0~65535	0m
P8.13	Actual length	0~65535m	0~65535	0m
P8.14	Number of pulse per cycle	1~10000	1~10000	1
P8.15	Perimeter of shaft	0.01~100.00cm	0.01~100.00	10.00cm
P8.16	Ratio of length	0.001~10.000	0.001~10.000	1.000
P8.17	Coefficient of length correction	0.001~1.000	0.001~1.000	1.000

The inverter inputs counting pulses via HDI (P5.19 is set to be 1) and calculate length according to the number of pulses per cycle (P8.14) and perimeter of shaft (P8.15). The formula is as below:

Calculated length = (Number of pulses / number of pulse per cycle) * perimeter of shaft

The calculated length can be corrected through P8.16 (ratio of length) and P8.17 (coefficient of length correction), and the result is the actual length.

Actual length = calculated length * ratio of length / coefficient of length correction

When actual length (P8.13) ≥ preset length (P8.12), the inverter will send STOP command to stop the inverter. When the inverter restarts, it needs to clear or modify the actual length (P8.13), otherwise the inverter will not start.

Function Code	Name	Description	Setting Range	Factory Setting
P8.18	Preset count value	P8.19~65535	P8.19~65535	0
P8.19	Specified count value	0~P8.18	0~ P8.18	0

The count pulse input channel can be S1~S4 (≤200Hz) and HDI.

If function of output terminal is set as preset count reached, when the count value reaches preset count value (P8.18), it will output an ON-OFF signal. Inverter will clear the counter and restart counting.

If function of output terminal is set as specified count reached, when the count value reaches specified count value (P8.19), it will output an ON-OFF signal until the count value reaches preset count value (P8.18). Inverter will clear the counter and restart counting.

Notice:

- **Specified count value (P8.19) should not be greater than preset count value (P8.18).**
- **Output terminal can be RO1, RO2 or HDO.**

This function is shown as following figure.

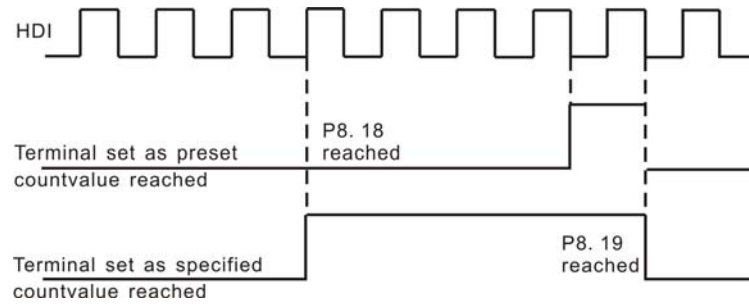

Figure 6.19 Timing chart for preset and specified count reached.

Function Code	Name	Description	Setting Range	Factory Setting
P8.20	Preset running time	0~65535h	0~65535	65535 h

If function of output terminal is set as running time reached, when the accumulated running time reaches the preset running time, it will output an ON-OFF signal.

Function Code	Name	Description	Setting Range	Factory Setting
P8.21	FDT level	0.00~ P0.04	0.00~ P0.04	50.00Hz
P8.22	FDT lag	0.0~100.0%	0.0~100.0	5.0%

When the output frequency reaches a certain preset frequency (FDT level), output terminal will output an ON-OFF signal until output frequency drops below a certain frequency of FDT level (FDT level - FDT lag), as shown in following figure.

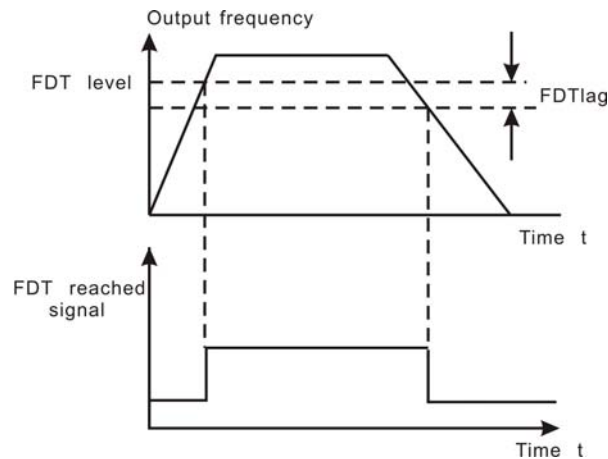

Figure 6.20 FDT level and lag diagram.

Detailed Function Description

Function Code	Name	Description	Setting Range	Factory Setting
P8.23	Frequency arrive detecting range	0.0~100.0% (maximum frequency)	0.0~100.0	0.0%

When output frequency is within the detecting range of reference frequency, an ON-OFF signal will be output.

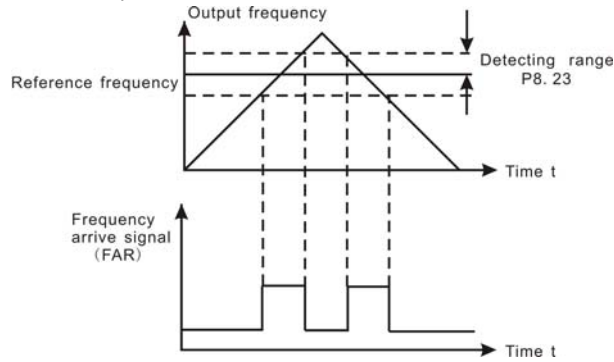

Figure 6.21 Frequency arriving detection diagram.

Function Code	Name	Description	Setting Range	Factory Setting
P8.24	Droop control	0.00~10.00Hz	0.00~10.00	0.00Hz

When several motors drive the same load, each motor's load is different because of the difference of motor's rated speed. The load of different motors can be balanced through droop control function which makes the speed droop along with load increasing.

When the motor outputs rated torque, actual frequency drop is equal to P8.24. User can adjust this parameter from small to big gradually during commissioning. The relation between load and output frequency is in the following figure.

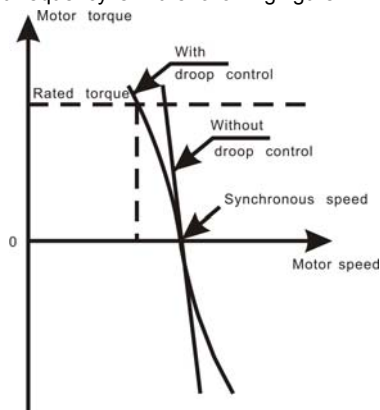

Figure 6.22 Droop control diagram.

Function Code	Name	Description	Setting Range	Factory Setting
P8.25	Auxiliary motor selection	0: Invalid 1: Motor 1 valid 2: Motor 2 valid 3: Both valid	0~3	0
P8.26	Auxiliary motor1 START/STOP delay time	0.0~3600.0s	0.0~3600.0	5.0s
P8.27	Auxiliary motor2 START/STOP delay time	0.0~3600.0s	0.0~3600.0	5.0s

Above parameters are used to realize simple water supply control function which one inverter drives three pumps (one variable-frequency pump and two power-frequency pumps). The control logic is shown in the following figure.

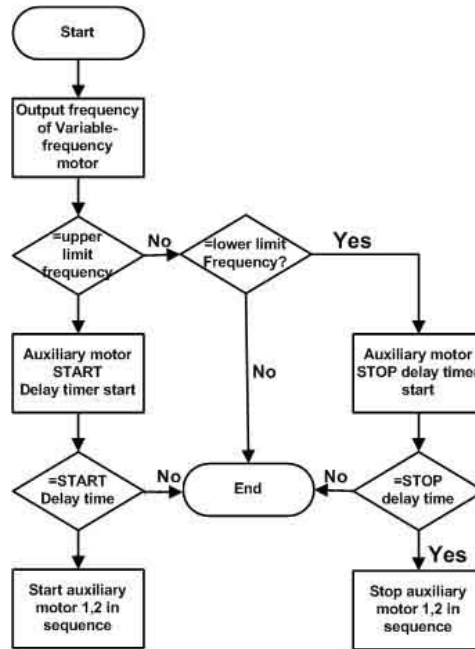

Figure 6.23 Simple water-supply control function diagram.

Notice:

- Delay time of start auxiliary motor and stop auxiliary motor are the same.
- PID control (P3.01=6) is necessary for simple water supply control.
- P1.12 should not be set to be 1.

Detailed Function Description

Function Code	Name	Description	Setting Range	Factory Setting
P8.28	Brake threshold voltage	115.0~140.0%	115.0~140.0	Depend on model

When the DC bus voltage is greater than the value of P8.28, the inverter will start dynamic braking.

Notice:

- **Factory setting is 120% if rated voltage of inverter is 220V.**
- **Factory setting is 130% if rated voltage of inverter is 380V.**
- **The value of P8.28 is corresponding to the DC bus voltage at rated input voltage.**

Function Code	Name	Description	Setting Range	Default Value
P8.29	Cooling fan control	0: Auto stop mode 1: Always working	0~1	0

0: Auto stop mode: The fan keeps working when the inverter is running. When the inverter stops, whether the fan work or not depends on the internal temperature of inverter.

Function Code	Name	Description	Setting Range	Factory Setting
P8.30	Restrain oscillation	0: Enabled 1: Disabled	0~1	1

Motor always has current oscillation when its load is light. This will cause abnormal operation even over-current. For details, please refer to description of PD.00~PD.03.

Function Code	Name	Description	Setting range	Factory Setting
P8.31	PWM mode	0: PWM mode 1 1: PWM mode 2 2: PWM mode 3	0~2	0

The features of each mode, please refer the following table:

Mode	Noise in lower frequency	Noise in higher frequency	Others
PWM mode 1	Low	high	
PWM mode 2	low		Need to be derated, because of higher temperature rise.
PWM mode 3	high		Can more effectively restrain the oscillation

6.10 P9 Group--PID Control

PID control is a common used method in process control, such as flow, pressure and temperature control. The principle is firstly detect the bias between preset value and feedback value, then calculate output frequency of inverter according to proportional gain, integral and differential time. Please refer to following figure.

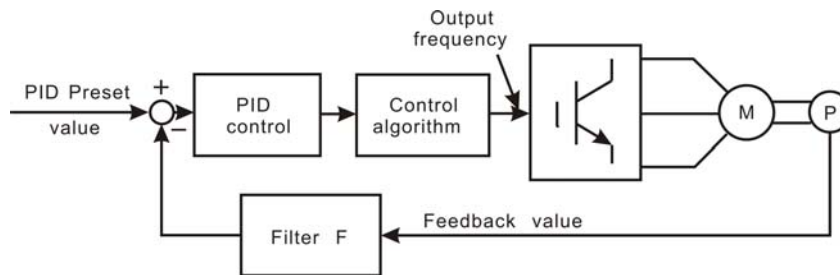

Figure 6.24 PID control diagram.

Notice: To make PID take effect, P3.01 must be set to be 6.

Function Code	Name	Description	Setting range	Factory Setting
P9.00	PID preset source selection	0: Keypad 1: AI1 2: AI2 3: HDI 4: Multi-step 5: Communication	0~5	0
P9.01	Keypad PID preset	0.0%~100.0%	0.0~100.0	0.0%
P9.02	PID feedback source selection	0: AI1 1: AI2 2: AI1+AI2 3: HDI 4: Communication	0~4	0

These parameters are used to select PID preset and feedback source.

Notice:

- **Preset value and feedback value of PID are percentage value.**
- **100% of preset value is corresponding to 100% of feedback value.**
- **Preset source and feedback source must not be same, otherwise PID will be malfunction.**

Function Code	Name	Description	Setting range	Factory Setting
P9.03	PID output characteristic	0: Positive 1: Negative	0~1	0

0: Positive. When the feedback value is greater than the preset value, output frequency will be decreased, such as tension control in winding application.

Detailed Function Description

1: Negative. When the feedback value is greater than the preset value, output frequency will be increased, such as tension control in unwinding application.

Function Code	Name	Description	Setting range	Factory Setting
P9.04	Proportional gain (Kp)	0.00~100.00	0.00~100.00	0.10
P9.05	Integral time (Ti)	0.01~10.00s	0.01~10.00	0.10s
P9.06	Differential time (Td)	0.00~10.00s	0.00~10.00	0.00s

Optimize the responsiveness by adjusting these parameters while driving an actual load.

Adjusting PID control:

Use the following procedure to activate PID control and then adjust it while monitoring the response.

1. Enabled PID control (P3.01=6)
2. Increase the proportional gain (Kp) as far as possible without creating oscillation.
3. Reduce the integral time (Ti) as far as possible without creating oscillation.
4. Increase the differential time (Td) as far as possible without creating oscillation.

Making fine adjustments:

First set the individual PID control constants, and then make fine adjustments.

- Reducing overshooting

If overshooting occurs, shorten the differential time and lengthen the integral time.

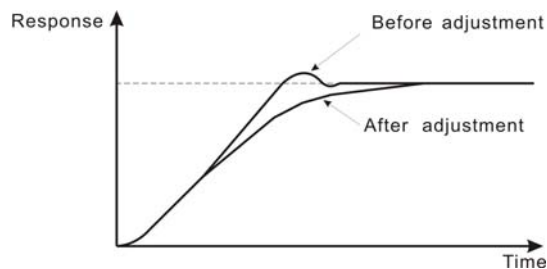

Figure 6.25 Reducing overshooting diagram.

- Rapidly stabilizing control status

To rapidly stabilize the control conditions even when overshooting occurs, shorten the integral time and lengthen the differential time.

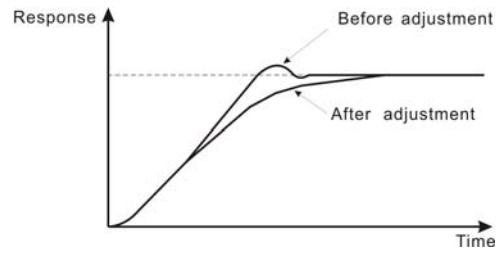

Figure 6.26 Rapidly stabilizing diagram.

- Reducing long-cycle oscillation

If oscillation occurs with a longer cycle than the integral time setting, it means that integral operation is strong. The oscillation will be reduced as the integral time is lengthened.

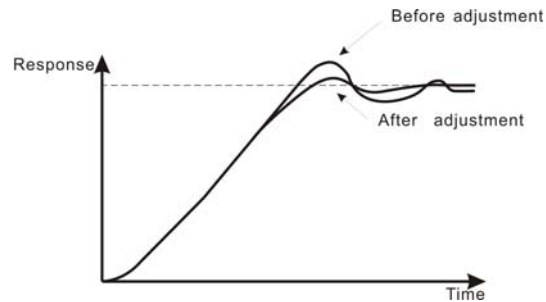

Figure 6.27 Reducing long-cycle oscillation diagram.

- Reducing short-cycle oscillation

If the oscillation cycle is short and oscillation occurs with a cycle approximately the same as the differential time setting, it means that the differential operation is strong. The oscillation will be reduced as the differential time is shortened.

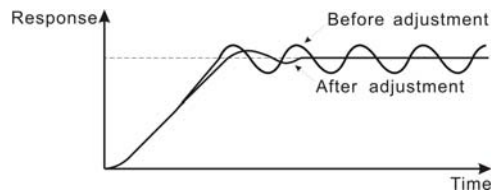

Figure 6.28 Reducing short-cycle oscillation diagram.

If oscillation cannot be reduced even by setting the differential time to 0, then either lower the proportional gain or raise the PID primary delay time constant.

Detailed Function Description

Function Code	Name	Description	Setting range	Factory Setting
P9.07	Sampling cycle (T)	0.01~100.00s	0.01~100.00	0.10s
P9.08	Bias limit	0.0~100.0%	0.0~100.0	0.0%

Sampling cycle T refers to the sampling cycle of feedback value. The PI regulator calculates once in each sampling cycle. The bigger the sampling cycle, the slower the response is.

Bias limit defines the maximum bias between the feedback and the preset. PID stops operation when the bias is within this range. Setting this parameter correctly is helpful to improve the system output accuracy and stability.

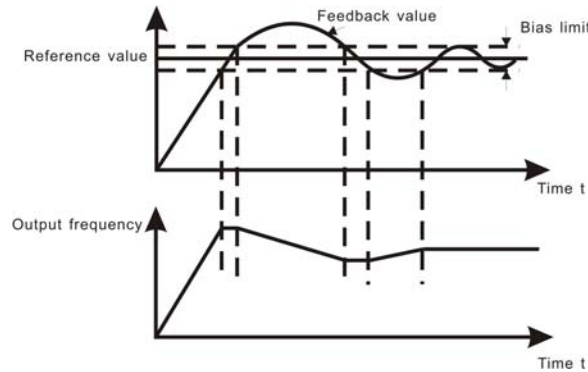

Figure 6.29 Relationship between bias limit and output frequency.

Function Code	Name	Description	Setting range	Factory Setting
P9.09	Feedback lost detecting value	0.0~100.0%	0.0~100.0	0.0%
P9.10	Feedback lost detecting time	0.0~3600.0s	0.0~3600.0	1.0s

When feedback value is less than P9.09 continuously for the period determined by P9.10, the inverter will alarm feedback lost failure (PIDE). **Notice: 100% of P9.09 is the same as 100% of P9.01.**

6.11 PA Group--Simple PLC and Multi-steps Speed Control

Simple PLC function can enable the inverter change its output frequency and directions automatically according to preset running time. For multi-step speed function, the output frequency can be changed only by multi-step terminals.

Notice:

- Simple PLC has 16 steps which can be selected.
- If P3.01 is set to be 5, 16 steps are available for multi-step speed. Otherwise only 15 steps are available (step 1~15).

Function Code	Name	Description	Setting range	Factory Setting
PA.00	Simple PLC mode	0: Stop after one cycle 1: Hold last frequency after one cycle 2: Circular run	0~2	0

0: Stop after one cycle: Inverter stops automatically as soon as it completes one cycle, and it is needed to give run command to start again.

1: Hold last frequency after one cycle: Inverter holds frequency and direction of last step after one cycle.

2: Circular run: Inverter continues to run cycle by cycle until receive a stop command.

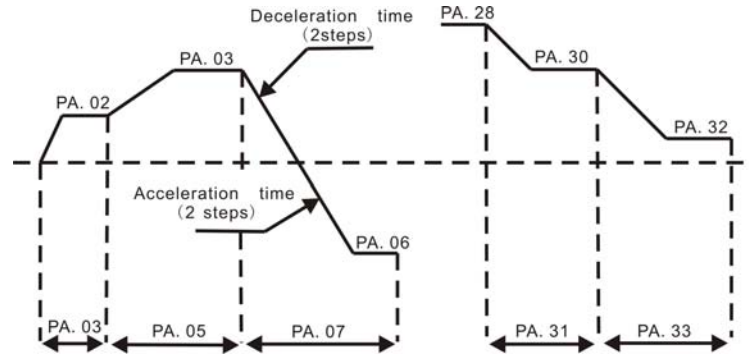

Figure 6.30 Simple PLC operation diagram.

Function Code	Name	Description	Setting range	Factory Setting
PA.01	Simple PLC status saving after power off	0: Disabled 1: Enabled	0~1	0

This parameter determines whether the running step and output frequency should be saved when power off or not.

Function Code	Name	Description	Setting range	Factory Setting
PA.02	Multi-step speed 0	-100.0~100.0%	-100.0~100.0	0.0%
PA.03	0 th Step running time	0.0~6553.5 s(m)	0.0~6553.5	0.0s
PA.04	Multi-step speed 1	-100.0~100.0%	-100.0~100.0	0.0%
PA.05	1 st Step running time	0.0~6553.5 s(m)	0.0~6553.5	0.0s
PA.06	Multi-step speed 2	-100.0~100.0%	-100.0~100.0	0.0%

Detailed Function Description

PA.07	2 nd Step running time	0.0~6553.5 s(m)	0.0~6553.5	0.0s
PA.08	Multi-step speed 3	-100.0~100.0%	-100.0~100.0	0.0%
PA.09	3 rd Step running time	0.0~6553.5 s(m)	0.0~6553.5	0.0s
PA.10	Multi-step speed 4	-100.0~100.0%	-100.0~100.0	0.0%
PA.11	4 th Step running time	0.0~6553.5 s(m)	0.0~6553.5	0.0s
PA.12	Multi-step speed 5	-100.0~100.0%	-100.0~100.0	0.0%
PA.13	5 th Step running time	0.0~6553.5 s(m)	0.0~6553.5	0.0s
PA.14	Multi-step speed 6	-100.0~100.0%	-100.0~100.0	0.0%
PA.15	6 th Step running time	0.0~6553.5 s(m)	0.0~6553.5	0.0s
PA.16	Multi-step speed 7	-100.0~100.0%	-100.0~100.0	0.0%
PA.17	7 th Step running time	0.0~6553.5 s(m)	0.0~6553.5	0.0s
PA.18	Multi-step speed 8	-100.0~100.0%	-100.0~100.0	0.0%
PA.19	8 th Step running time	0.0~6553.5 s(m)	0.0~6553.5	0.0s
PA.20	Multi-step speed 9	-100.0~100.0%	-100.0~100.0	0.0%
PA.21	9 th Step running time	0.0~6553.5 s(m)	0.0~6553.5	0.0s
PA.22	Multi-step speed 10	-100.0~100.0%	-100.0~100.0	0.0%
PA.23	10 th Step running time	0.0~6553.5 s(m)	0.0~6553.5	0.0s
PA.24	Multi-step speed 11	-100.0~100.0%	-100.0~100.0	0.0%
PA.25	11 th Step running time	0.0~6553.5 s(m)	0.0~6553.5	0.0s
PA.26	Multi-step speed 12	-100.0~100.0%	-100.0~100.0	0.0%
PA.27	12 th Step running time	0.0~6553.5 s(m)	0.0~6553.5	0.0s
PA.28	Multi-step speed 13	-100.0~100.0%	-100.0~100.0	0.0%
PA.29	13 th Step running time	0.0~6553.5 s(m)	0.0~6553.5	0.0s
PA.30	Multi-step speed 14	-100.0~100.0%	-100.0~100.0	0.0%
PA.31	14 th Step running time	0.0~6553.5 s(m)	0.0~6553.5	0.0s
PA.32	Multi-step speed 15	-100.0~100.0%	-100.0~100.0	0.0%
PA.33	15 th Step running time	0.0~6553.5 s(m)	0.0~6553.5	0.0s

Notice:

- 100% of multi-step speed x corresponds to the maximum frequency (P0.04).
- If the value of multi-step speed x is negative, the direction of this step will be reverse, otherwise it will be forward.
- The unit of x step running time is determined by PA.37.

Selection of step is determined by combination of multi-step terminals. Please refer to following figure and table.

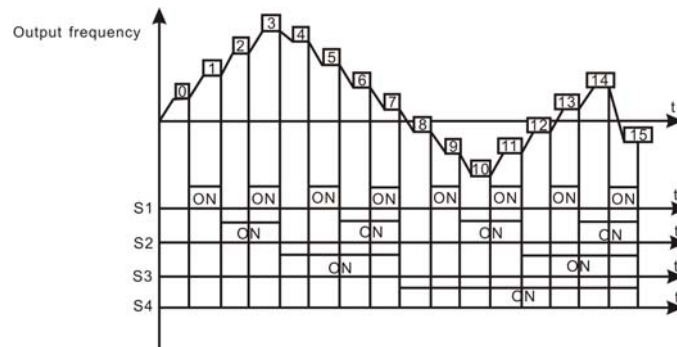

Figure 6.31 Multi-steps speed operation diagram.

Terminal Step	Multi-step speed reference1	Multi-step speed reference2	Multi-step speed reference3	Multi-step speed reference4
0	OFF	OFF	OFF	OFF
1	ON	OFF	OFF	OFF
2	OFF	ON	OFF	OFF
3	ON	ON	OFF	OFF
4	OFF	OFF	ON	OFF
5	ON	OFF	ON	OFF
6	OFF	ON	ON	OFF
7	ON	ON	ON	OFF
8	OFF	OFF	OFF	ON
9	ON	OFF	OFF	ON
10	OFF	ON	OFF	ON
11	ON	ON	OFF	ON
12	OFF	OFF	ON	ON
13	ON	OFF	ON	ON
14	OFF	ON	ON	ON
15	ON	ON	ON	ON

Detailed Function Description

Function Code	Name	Description	Setting range	Factory Setting
PA.34	ACC/DEC time selection for step 0~7	0~0XFFFF	0~0XFFFF	0
PA.35	ACC/DEC time selection for step 8~15	0~0XFFFF	0~0XFFFF	0

These parameters are used to determine the ACC/DEC time from one step to next step.

There are four ACC/DEC time groups.

Function Code	Binary Digit		Step No.	ACC/DEC Time 0	ACC/DEC Time 1	ACC/DEC Time 2	ACC/DEC Time 3
PA.34	BIT1	BIT0	0	00	01	10	11
	BIT3	BIT2	1	00	01	10	11
	BIT5	BIT4	2	00	01	10	11
	BIT7	BIT6	3	00	01	10	11
	BIT9	BIT8	4	00	01	10	11
	BIT11	BIT10	5	00	01	10	11
	BIT13	BIT12	6	00	01	10	11
PA.35	BIT15	BIT14	7	00	01	10	11
	BIT1	BIT0	8	00	01	10	11
	BIT3	BIT2	9	00	01	10	11
	BIT5	BIT4	10	00	01	10	11
	BIT7	BIT6	11	00	01	10	11
	BIT9	BIT8	12	00	01	10	11
	BIT11	BIT10	13	00	01	10	11
BIT13	BIT12	14	00	01	10	11	
BIT15	BIT14	15	00	01	10	11	

For example: To set the acceleration time of following table:

Step No.	0	1	2	3	4	5	6	7	8	9	10	11	12	13	14	15
ACC/DEC time group	0	1	2	3	2	1	3	0	3	3	2	0	0	0	2	2

The value of every bit of PA.34 and PA.35 is:

Low byte	BIT 0	BIT 1	BIT 2	BIT 3	BIT 4	BIT 5	BIT 6	BIT 7
PA.34	0	0	1	0	0	1	1	1
PA.35	1	1	1	1	0	1	0	0
High byte	BIT 8	BIT 9	BIT 10	BIT 11	BIT 12	BIT 13	BIT 14	BIT 15
PA.34	0	1	1	0	1	1	0	0
PA.35	0	0	0	0	0	1	0	1

So the value of PA.34 should be: 0X36E4, the value of PA.35 should be: 0XA02F

Function Code	Name	Description	Setting range	Factory Setting
PA.36	Simple PLC restart selection	0: Restart from step 0 1: Continue from paused step	0~1	0

0: Restart from step 0: If the inverter stops during running (due to stop command or fault), it will run from step 0 when it restarts.

1: Continue from paused step: If the inverter stops during running (due to stop command or fault), it will record the running time of current step. When inverter restarts, it will resume from paused time automatically. For details, please refer to following figure.

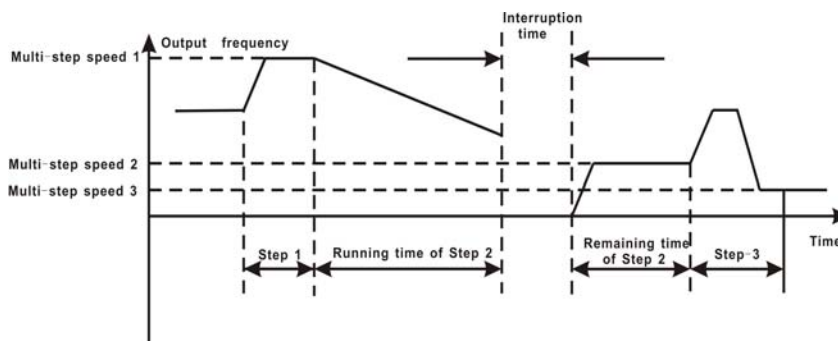

Figure 6.32 Simple PLC continue from paused step.

Function Code	Name	Description	Setting range	Factory Setting
PA.37	Time unit	0: Second 1: Minute	0~1	0

This parameter determines the unit of x step running time.

6.12 PB Group-- Protection Function

Function Code	Name	Description	Setting range	Factory Setting
PB.00	Input phase-failure protection	0: Disable 1: Enable	0~1	1
PB.01	Output phase-failure protection	0: Disable 1: Enable	0~1	1

Notice: Please be cautious to set these parameters as disabled. Otherwise it may cause inverter and motor overheat even damaged.

Function Code	Name	Description	Setting range	Factory Setting
PB.02	Motor overload protection	0: Disabled 1: Normal motor 2: Variable frequency motor	0~2	2

1: For normal motor, the lower the speed, the poorer the cooling effect. Based on this reason, if output frequency is lower than 30Hz, inverter will reduce the motor overload protection threshold to prevent normal motor from overheat.

2: As the cooling effect of variable frequency motor has nothing to do with running speed, it is not required to adjust the motor overload protection threshold.

Function Code	Name	Description	Setting range	Factory Setting
PB.03	Motor overload protection current	20.0%~120.0%	20.0~120.0	100.0%

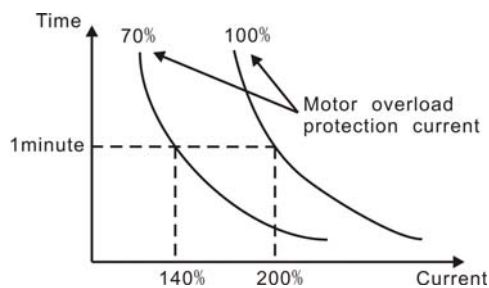

Figure 6.33 Motor overload protection curve.

The value can be determined by the following formula:

$$\text{Motor overload protection current} = (\text{motor rated current} / \text{inverter rated current}) * 100\%$$

Notice:

- This parameter is normally used when rated power of inverter is greater than rated power of motor.
- Motor overload protection time: 60s with 200% of rated current. For details, please refer to above figure.

Function Code	Name	Description	Setting range	Factory Setting
PB.04	Threshold of trip-free	70.0~110.0%	70.0~110.0	80.0%
PB.05	Decrease rate of trip-free	0.00Hz~P0.04	0.00Hz~P0.04	0.00Hz

If PB.05 is set to be 0, the trip-free function is invalid.

Trip-free function enables the inverter to perform low-voltage compensation when DC bus voltage drops below PB.04. The inverter can continue to run without tripping by reducing its output frequency and feedback energy via motor.

Notice: If PB.05 is too big, the feedback energy of motor will be too large and may cause over-voltage fault. If PB.05 is too small, the feedback energy of motor will be too small to achieve voltage compensation effect. So please set PB.05 according to load inertia and the actual load.

Function Code	Name	Description	Setting range	Factory Setting
PB.06	Over-voltage stall protection	0: Disabled 1: Enabled	0~1	1
PB.07	Over-voltage stall protection point	110~150%	110~150	380V:130% 220V:120%

During deceleration, the motor's decelerating rate may be lower than that of inverter's output frequency due to the load inertia. At this time, the motor will feed the energy back to the inverter, resulting in DC bus voltage rise. If no measures taken, the inverter will trip due to over voltage.

During deceleration, the inverter detects DC bus voltage and compares it with over-voltage stall protection point. If DC bus voltage exceeds PB.07, the inverter will stop reducing its output frequency. When DC bus voltage become lower than PB.07, the deceleration continues, as shown in following figure.

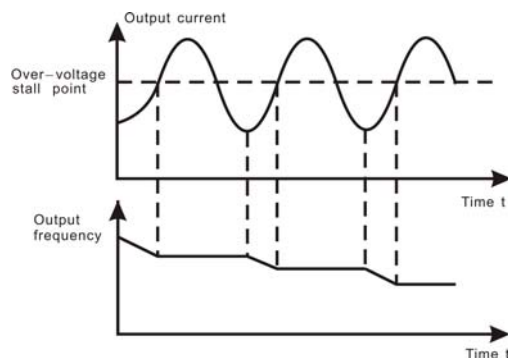

Figure 6.34 Over-voltage stall function.

Detailed Function Description

Function Code	Name	Description	Setting range	Factory Setting
PB.08	Auto current limiting threshold	50~200%	50~200	G Model: 160% P Model: 120%
PB.09	Frequency decrease rate when current limiting	0.00~100.00Hz/s	0.00~100.00	10.00Hz/s
PB.10	Auto current limiting selection	0: Enabled 1: Disabled when constant speed	0~1	0

Auto current limiting is used to limit the current of inverter smaller than the value determined by PB.08 in real time. Therefore the inverter will not trip due to surge over-current. This function is especially useful for the applications with big load inertia or step change of load.

PB.08 is a percentage of the inverter's rated current.

PB.09 defines the decrease rate of output frequency when this function is active. If PB.08 is too small, overload fault may occur. If it is too big, the frequency will change too sharply and therefore, the feedback energy of motor will be too large and may cause over-voltage fault. This function is always enabled during acceleration or deceleration. Whether the function is enabled in constant

Speed running is determined by PB.10.

Notice:

- **During auto current limiting process, the inverter's output frequency may change; therefore, it is recommended not to enable the function when requires the inverter's output frequency stable.**
- **During auto current limiting process, if PB.08 is too low, the overload capacity will be impacted.**

Please refer to following figure.

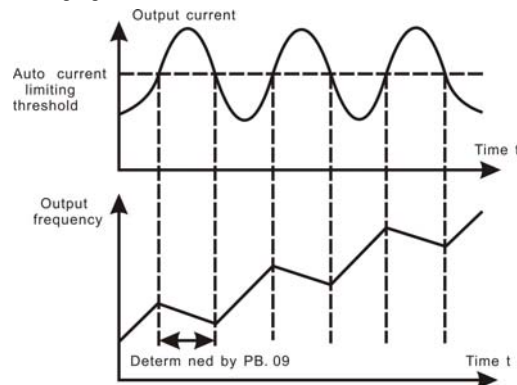

Figure 6.35 Current limiting protection function.

6.13 PC Group--Serial Communication

Function Code	Name	Description	Setting range	Factory Setting
PC.00	Local address	1~247	0~247	1

This parameter determines the slave address used for communication with master. The value "0" is the broadcast address.

Function Code	Name	Description	Setting range	Factory Setting
PC.01	Baud rate selection	0: 1200BPS 1: 2400BPS 2: 4800BPS 3: 9600BPS 4: 19200BPS 5: 38400BPS	0~5	3

This parameter can set the data transmission rate during serial communication.

Notice: The baud rate of master and slave must be the same.

Function Code	Name	Description	Setting range	Factory Setting
PC.02	Data format	0~17	0~17	1

This parameter defines the data format used in serial communication protocol.

- 0: RTU, 1 start bit, 8 data bits, no parity check, 1 stop bit.
- 1: RTU, 1 start bit, 8 data bits, even parity check, 1 stop bit.
- 2: RTU, 1 start bit, 8 data bits, odd parity check, 1 stop bit.
- 3: RTU, 1 start bit, 8 data bits, no parity check, 2 stop bits.
- 4: RTU, 1 start bit, 8 data bits, even parity check, 2 stop bits.
- 5: RTU, 1 start bit, 8 data bits, odd parity check, 2 stop bits.
- 6: ASCII, 1 start bit, 7 data bits, no parity check, 1 stop bit.
- 7: ASCII, 1 start bit, 7 data bits, even parity check, 1 stop bit.
- 8: ASCII, 1 start bit, 7 data bits, odd parity check, 1 stop bit.
- 9: ASCII, 1 start bit, 7 data bits, no parity check, 2 stop bits.
- 10: ASCII, 1 start bit, 7 data bits, even parity check, 2 stop bits.
- 11: ASCII, 1 start bit, 7 data bits, odd parity check, 2 stop bits.
- 12: ASCII, 1 start bit, 8 data bits, no parity check, 1 stop bit.
- 13: ASCII, 1 start bit, 8 data bits, even parity check, 1 stop bit.
- 14: ASCII, 1 start bit, 8 data bits, odd parity check, 1 stop bit.
- 15: ASCII, 1 start bit, 8 data bits, no parity check, 2 stop bits.
- 16: ASCII, 1 start bit, 8 data bits, even parity check, 2 stop bits.
- 17: ASCII, 1 start bit, 8 data bits, odd parity check, 2 stop bits.

Detailed Function Description

Function Code	Name	Description	Setting range	Factory Setting
PC.03	Communication delay time	0~200ms	0~200	5ms

This parameter can be used to set the response delay in communication in order to adapt to the MODBUS master. In RTU mode, the actual communication delay should be no less than 3.5 characters' interval; in ASCII mode, 1ms.

Function Code	Name	Description	Setting range	Factory Setting
PC.04	Communication timeout delay	0.0: Disabled 0.1~100.0s	0~100.0	0.0s

When the value is zero, this function will be disabled. When communication interruption is longer than the non-zero value of PC.04, the inverter will alarm communication error (CE).

Function Code	Name	Description	Setting range	Factory Setting
PC.05	Communication error action	0: Alarm and coast to stop 1: No alarm and continue to run 2: No alarm but stop according to P1.06 (if P0.03=2) 3: No alarm but stop according to P1.06	0~3	1

0: When communication error occurs, inverter will alarm (CE) and coast to stop.

1: When communication error occurs, inverter will omit the error and continue to run.

2: When communication error occurs, if P0.03=2, inverter will not alarm but stop according to stop mode determined by P1.06. Otherwise it will omit the error.

3: When communication error occurs, inverter will not alarm but stop according to stop mode determined by P1.06.

Function Code	Name	Description	Setting range	Factory Setting
PC.06	Response action	Unit's place of LED 0: Response to writing 1: No response to writing Ten's place of LED 0: Reference not saved when power off 1: Reference saved when power off	0~1	0

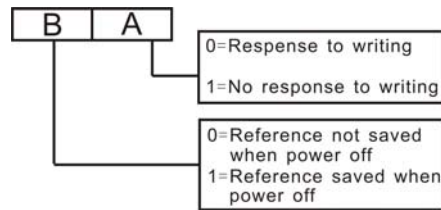

Figure 6.36 Meaning of PC.06.

A stands for: Unit's place of LED.

B stands for: Ten's place of LED

6.14 PD Group--Supplementary Function

Function Code	Name	Description	Setting range	Factory Setting
PD.00	Low-frequency threshold of restraining oscillation	0~500	0~500	5
PD.01	High-frequency threshold of restraining oscillation	0~500	0~500	100

This function is valid only when P8.30 is set to be 0. The smaller the value of PD.00 and PD.01, the stronger the restraining effect.

Notice: Most motor may have current oscillation at some frequency point. Please be cautious to adjust these parameters to weaken oscillation.

Function Code	Name	Description	Setting range	Factory Setting
PD.02	Amplitude of restraining oscillation	0~10000	0~10000	5000

This parameter is used to limit the strength of restraining oscillation. If the value of PD.02 is too big, it may cause inverter over current. It should be set a little bit smaller for large power motor, vice versa.

Function Code	Name	Description	Setting range	Factory Setting
PD.03	Boundary of restraining oscillation	0.0~P0.04	0.0HZ~P0.04	12.5HZ

If output frequency is greater than PD.03, PD.00 takes effect, otherwise PD.01 takes effect.

Detailed Function Description

Function Code	Name	Description	Setting range	Factory Setting
PD.04	Over-modulation selection	0: Disabled 1: Enabled	0~1	0

When the input voltage is lower than 85% of rated voltage or the inverter has driven a heavy load for a long time, the inverter can increase its output voltage by specific control algorithm.

6.15 PE Group—Factory Setting

This group is the factory-set parameter group. It is prohibited for user to access.

7. TROUBLE SHOOTING

7.1 Fault and Trouble shooting

Fault Code	Fault Type	Reason	Solution
OUT1	IGBT Ph-U fault	<ol style="list-style-type: none"> 1. Acc/Dec time is too short. 2. IGBT module fault. 3. Malfunction caused by interference. 4. Grounding is not properly. 	<ol style="list-style-type: none"> 1. Increase Acc/Dec time. 2. Ask for support. 3. Inspect external equipment and eliminate interference.
OUT2	IGBT Ph-V fault		
OUT3	IGBT Ph-W fault		
OC1	Over-current when acceleration	<ol style="list-style-type: none"> 1. Short-circuit or ground fault occurred at inverter output. 2. Load is too heavy or Acc/Dec time is too short. 3. V/F curve is not suitable. 4. Sudden change of load. 	<ol style="list-style-type: none"> 1. Inspect whether motor damaged, insulation worn or cable damaged. 2. Increase Acc/Dec time or select bigger capacity inverter. 3. Check and adjust V/F curve. 4. Check the load.
OC2	Over-current when deceleration		
OC3	Over-current when constant speed running		
OV1	Over-voltage when acceleration	<ol style="list-style-type: none"> 1. Dec time is too short and regenerative energy from the motor is too large. 2. Input voltage is too high. 	<ol style="list-style-type: none"> 1. Increase Dec time or connect braking resistor 2. Decrease input voltage within specification.
OV2	Over-voltage when deceleration		
OV3	Over-voltage when constant speed running		
UV	DC bus Under-voltage	<ol style="list-style-type: none"> 1. Open phase occurred with power supply. 2. Momentary power loss occurred 3. Wiring terminals for input power supply are loose. 4. Voltage fluctuations in power supply are too large. 	Inspect the input power supply or wiring.
OL1	Motor overload	<ol style="list-style-type: none"> 1. Motor drive heavy load at low speed for a long time. 2. Improper V/F curve 3. Improper motor's overload protection threshold (PB.03) 4. Sudden change of load. 	<ol style="list-style-type: none"> 1. Select variable frequency motor. 2. Check and adjust V/F curve. 3. Check and adjust PB.03 4. Check the load.

Trouble Shooting

OL2	Inverter overload	<ol style="list-style-type: none"> 1. Load is too heavy or Acc/Dec time is too short. 2. Improper V/F curve 3. Capacity of inverter is too small. 	<ol style="list-style-type: none"> 1. Increase Acc/Dec time or select bigger capacity inverter. 2. Check and adjust V/F curve. 3. Select bigger capacity inverter.
SPI	Input phase failure	<ol style="list-style-type: none"> 1. Open-phase occurred in power supply. 2. Momentary power loss occurred. 3. Wiring terminals for input power supply are loose. 4. Voltage fluctuations in power supply are too large. 5. Voltage balance between phase is bad. 	Check the wiring, installation and power supply.
SPO	Output phase failure	<ol style="list-style-type: none"> 1. There is a broken wire in the output cable 2. There is a broken wire in the motor winding. 3. Output terminals are loose. 	Check the wiring and installation.
EF	External fault	Sx: External fault input terminal take effect.	Inspect external equipment.
OH1	Rectify overheat	<ol style="list-style-type: none"> 1. Ambient temperature is too high. 2. Near heat source. 3. Cooling fans of inverter stop or damaged. 4. Obstruction of ventilation channel 	<ol style="list-style-type: none"> 1. Install cooling unit. 2. Remove heat source. 3. Replace cooling fan 4. Clear the ventilation channel. 5. Decrease carrier frequency.
OH2	IGBT overheat	<ol style="list-style-type: none"> 5. Carrier frequency is too high. 	
CE	Communication fault	<ol style="list-style-type: none"> 1. Improper baud rate setting. 2. Receive wrong data. 3. Communication is interrupted for Long time 	<ol style="list-style-type: none"> 1. Set proper baud rate. 2. Check communication devices and signals.
ITE	Current detection fault	<ol style="list-style-type: none"> 1. Wires or connectors of control board are loose 2. Hall sensor is damaged. 3. Amplifying circuit is abnormal. 	<ol style="list-style-type: none"> 1. Check the wiring. 2. Ask for support.
TE	Autotuning fault	<ol style="list-style-type: none"> 1. Improper setting of motor rated parameters. 2. Overtime of autotuning. 	<ol style="list-style-type: none"> 1. Set rated parameters according to motor nameplate. 2. Check motor's wiring.

EEP	EEPROM fault	Read/Write fault of control parameters	Press STOP/RESET to reset Ask for support
PIDE	PID feedback fault	1. PID feedback disconnected. 2. PID feedback source disappears.	1. Inspect PID feedback signal wire. 2. Inspect PID feedback source.
BCE	Brake unit fault	1. Braking circuit failure or brake tube damaged. 2. Too low resistance of externally connected braking resistor.	1. Inspect braking unit, replace braking tube. 2. Increase braking resistance.
	Factory Reserved		

7.2 Common Faults and Solutions

Inverter may have following faults or malfunctions during operation, please refer to the following solutions.

No display after power on:

- Inspect whether the voltage of power supply is the same as the inverter rated voltage or not with multi-meter. If the power supply has problem, inspect and solve it.
- Inspect whether the three-phase rectify bridge is in good condition or not. If the rectification bridge is burst out, ask for support.
- Check the CHARGE light. If the light is off, the fault is mainly in the rectify bridge or the buffer resistor. If the light is on, the fault may be lies in the switching power supply. Please ask for support.

Power supply air switch trips off when power on:

- Inspect whether the input power supply is grounded or short circuit. Please solve the problem.
- Inspect whether the rectify bridge has been burnt or not. If it is damaged, ask for support.

Motor doesn't move after inverter running:

- Inspect if there is balanced three-phase output among U, V, W. If yes, then motor could be damaged, or mechanically locked. Please solve it.
- If the output is unbalanced or lost, the inverter drive board or the output module may be damaged, ask for support..

Inverter displays normally when power on, but switch at the input side trips when running:

- Inspect whether the output side of inverter is short circuit. If yes, ask for support.
- Inspect whether ground fault exists. If yes, solve it.
- If trip happens occasionally and the distance between motor and inverter is too far, it is recommended to install output AC reactor.

8. MAINTENANCE



WARNING

- Maintenance must be performed according to designated maintenance methods.
- Maintenance, inspection and replacement of parts must be performed only by certified person.
- After turning off the main circuit power supply, wait for 10 minutes before maintenance or inspection.
- DO NOT directly touch components or devices of PCB board. Otherwise inverter can be damaged by electrostatic.
- After maintenance, all screws must be tightened.

8.1 Daily Maintenance

In order to prevent the fault of inverter to make it operate smoothly in high-performance for a long time, user must inspect the inverter periodically (within half year). The following table indicates the inspection content.

Items to be checked	Main inspections		Criteria
	Inspection content	Frequency	Means/methods
Operation environment	1. temperature 2. humidity 3. dust 4. vapor 5. gases	1. point thermometer, hygrometer 2. observation 3. visual examination and smelling	1. ambient temperature shall be lower than 40°C, otherwise, the rated values should be decreased. Humidity shall meet the requirement 2. no dust accumulation, no traces of water leakage and no condensate. 3. no abnormal color and smell.
Inverter	1. vibration 2. cooling and heating 3. noise	1. point thermometer 2. comprehensive observation 3. listening	1. smooth operation without vibration. 2. fan is working in good condition. Speed and air flow are normal. No abnormal heat. 3. No abnormal noise

Motor	1. vibration 2. heat 3. noise	1. comprehensive observation 2. point thermometer 3. listening	1. No abnormal vibration and no abnormal noise. 2. No abnormal heat. 3. No abnormal noise.
Operation status parameters	1. power input voltage 2. inverter output voltage 3. inverter output current 4. internal temperature	1. voltmeter 2. rectifying voltmeter 3. ammeter 4. point thermometer	1. satisfying the specification 2. satisfying the specification 3. satisfying the specification 4. temperature rise is lower than 40°C

8.2 Periodic Maintenance

Customer should check the drive every 3 months or 6 months according to the actual environment

8.2.1 Check whether the screws of control terminals are loose. If so, tighten them with a screwdriver;

8.2.2 Check whether the main circuit terminals are properly connected; whether the mains cables are over heated;

8.2.3 Check whether the power cables and control cables are damaged, check especially for any wear on the cable tube;

8.2.4 Check whether the insulating tapes around the cable lugs are stripped;

8.2.5 Clean the dust on PCBs and air ducts with a vacuum cleaner;

8.2.6 For drives that have been stored for a long time, it must be powered on every 2 years. When supplying AC power to the drive, use a voltage regulator to raise the input voltage to rated input voltage gradually. The drive should be powered for 5 hours without load.

8.2.7 Before performing insulation tests, all main circuit input/output terminals should be short-circuited with conductors. Then proceed insulation test to the ground. Insulation test of single main circuit terminal to ground is forbidden; otherwise the drive might be damaged. Please use a 500V Mega-Ohm-Meter.

8.2.8 Before the insulation test of the motor, disconnect the motor from the drive to avoid damaging it.

8.3 Replacement of wearing parts

Fans and electrolytic capacitors are wearing part, please make periodic replacement to

Maintenance

ensure long term, safety and failure-free operation. The replacement periods are as follows:

- ◆ Fan: Must be replaced when using up to 20,000 hours;
- ◆ Electrolytic Capacitor: Must be replaced when using up to 30,000~40,000 hours.

9. LIST OF FUNCTION PARAMETERS

Notice:

- PE group is factory reserved, users are forbidden to access these parameters.
- The column “Modify” determines the parameter can be modified or not.
“○” indicates that this parameter can be modified all the time.
“◎” indicates that this parameter cannot be modified during the inverter is running.
“●” indicates that this parameter is read only.
- “Factory Setting” indicates the value of each parameter while restoring the factory parameters, but those detected parameters or record values cannot be restored.

Function Code	Name	Description	Factory Setting	Modify	Serial No.
P0 Group: Basic Function					
P0.00	G/P option	0: G model 1: P model	0	◎	0
P0.01	Rated power of inverter	0.4~900.0kW	Depend on model	●	1
P0.02	Rated current of inverter	0.4~2000.0A	Depend on model	●	2
P0.03	Run command source	0: Keypad (LED extinguishes) 1: Terminal (LED flickers) 2: Communication (LED lights up)	0	◎	3
P0.04	Maximum frequency	P0.05~400.00Hz	50.00Hz	◎	4
P0.05	Upper frequency limit	P0.06~ P0.04	50.00Hz	○	5
P0.06	Lower frequency limit	0.00 Hz ~ P0.05	0.00Hz	○	6
P0.07	Acceleration time 0	0.1~3600.0s	Depend on model	○	7
P0.08	Deceleration time 0	0.1~3600.0s	Depend on model	○	8
P0.09	V/F curve selection	0: Linear curve 1: User-defined curve 2: Torque_stepdown curve (1.3 order) 3: Torque_stepdown curve (1.7 order) 4: Torque_stepdown curve (2.0 order)	0	◎	9
P0.10	Torque boost	0.0%: (auto) 0.1%~10.0%	0.0%	○	10

List of Function Parameters

Function Code	Name	Description	Factory Setting	Modify	Serial No.
P0.11	Carrier frequency	0.5~15.0kHz	Depend on model	O	11
P0.12	Motor parameters autotuning	0: No action 1: Rotation autotuning 2: Static autotuning	0	⊗	12
P0.13	Restore parameters	0: No action 1: Restore factory setting 2: Clear fault records	0	⊗	13
P1 Group: Start and Stop Control					
P1.00	Start Mode	0: Start directly 1: DC braking and start 2: Speed tracking and start	0	⊗	14
P1.01	Starting frequency	0.00~10.00Hz	0.00Hz	⊗	15
P1.02	Hold time of starting frequency	0.0~50.0s	0.0s	⊗	16
P1.03	DC Braking current before start	0.0~150.0%	0.0%	⊗	17
P1.04	DC Braking time before start	0.0~50.0s	0.0s	⊗	18
P1.05	Acceleration / Deceleration mode	0: Linear 1: reserved	0	⊗	19
P1.06	Stop mode	0: Deceleration to stop 1: Coast to stop	0	O	20
P1.07	Starting frequency of DC braking	0.00~P0.04	0.00Hz	O	21
P1.08	Waiting time before DC braking	0.0~50.0s	0.0s	O	22
P1.09	DC braking current	0.0~150.0%	0.0%	O	23
P1.10	DC braking time	0.0~50.0s	0.0s	O	24
P1.11	Dead time of FWD/REV	0.0~3600.0s	0.0s	O	25
P1.12	Action when running frequency is less than lower frequency limit	0: Running at the lower frequency limit 1: Stop 2: Stand-by	0	⊗	26
P1.13	Restart after power off	0: Disabled 1: Enabled	0	O	27
P1.14	Delay time for restart	0.0~3600.0s	0.0s	O	28
P1.15	FWD/REV enable option when power on	0: Disabled 1: Enabled	0	O	29

List of Function Parameters

Function Code	Name	Description	Factory Setting	Modify	Serial No.
P1.16	Reserved		0	⊙	30
P1.17	Reserved		0	⊙	31
P1.18	Reserved		0	⊙	32
P2 Group: Motor Parameters					
P2.00	Motor rated power	0.4~900.0kW	Depend on model	⊙	33
P2.01	Motor rated frequency	0.01Hz~P0.04	50.00Hz	⊙	34
P2.02	Motor rated speed	0~36000rpm	Depend on model	⊙	35
P2.03	Motor rated voltage	0~2000V	Depend on model	⊙	36
P2.04	Motor rated current	0.8~2000.0A	Depend on model	⊙	37
P2.05	Motor stator resistance	0.001~65.535Ω	Depend on model	○	38
P2.06	Motor rotor resistance	0.001~65.535Ω	Depend on model	○	39
P2.07	Motor leakage inductance	0.1~6553.5mH	Depend on model	○	40
P2.08	Motor mutual inductance;	0.1~6553.5mH	Depend on model	○	41
P2.09	Current without load	0.01~655.35A	Depend on model	○	42
P3 Group: Frequency Setting					
P3.00	Keypad reference frequency	0.00 Hz ~ P0.04 (maximum frequency)	50.00Hz	○	43
P3.01	Frequency A command source	0: Keypad 1: AI1 2: AI2 3: HDI 4: Simple PLC 5: Multi-Step speed 6: PID 7: Communication	0	○	44

List of Function Parameters

Function Code	Name	Description	Factory Setting	Modify	Serial No.
P3.02	Frequency B command source	0: AI1 1: AI2 2: HDI	0	O	45
P3.03	Scale of frequency B command	0: Maximum frequency 1: Frequency A command	0	O	46
P3.04	Frequency command selection	0: A 1: B 2: A+B 3: Max (A, B)	0	O	47
P3.05	UP/DOWN setting	0: Valid, save UP/DOWN value when power off 1: Valid, do not save UP/DOWN value when power off 2: Invalid 3: Valid during running, clear when stop.	0	O	48
P3.06	Jog reference	0.00~P0.04	5.00Hz	O	49
P3.07	Jog acceleration time	0.1~3600.0s	Depend on model	O	50
P3.08	Jog deceleration time	0.1~3600.0s	Depend on model	O	51
P3.09	Skip frequency 1	0.00~P0.04	0.00Hz	O	52
P3.10	Skip frequency 2	0.00~P0.04	0.00Hz	O	53
P3.11	Skip frequency bandwidth	0.00~P0.04	0.00Hz	O	54
P4 Group: V/F Control					
P4.00	Running direction selection	0: Forward 1: Reverse 2: Forbid reverse	0	⊙	55
P4.01	PWM mode	0: Fixed 1: Random	0	O	56
P4.02	Carrier frequency adjust based on temperature	0: Disabled 1: Enabled	0	⊙	57
P4.03	AVR function	0: Disabled 1: Enabled all the time 2: Disabled during deceleration	1	O	58
P4.04	Slip compensation limit	0.00~200.0%	0.0%	O	59

List of Function Parameters

Function Code	Name	Description	Factory Setting	Modify	Serial No.
P4.05	Auto energy saving selection	0: Disabled 1: Enabled	0	⊙	60
P4.06	Torque boost cut-off	0.0%~50.0% (motor rated frequency)	20.0%	⊙	61
P4.07	V/F frequency 1	0.00Hz~P4.09	5.00Hz	○	62
P4.08	V/F voltage 1	0.0% ~ 100.0% (rated voltage of motor)	10.0%	⊙	63
P4.09	V/F frequency 2	P4.07~ P4.11	30.00Hz	○	64
P4.10	V/F voltage 2	0.0% ~ 100.0% (rated voltage of motor)	60.0%	⊙	65
P4.11	V/F frequency 3	P4.09~ P2.01	50.00Hz	○	66
P4.12	V/F voltage 3	0.0% ~ 100.0% (rated voltage of motor)	100.0%	⊙	67
P5 Group: Input Terminals					
P5.00	HDI selection	0: High speed pulse input 1: ON-OFF input	0	⊙	68
P5.01	S1 Terminal function	0: Invalid 1: Forward 2: Reverse	1	⊙	69
P5.02	S2 Terminal function	3: 3-wire control 4: Jog forward 5: Jog reverse	4	⊙	70
P5.03	S3 Terminal function	6: Coast to stop 7: Reset fault 8: Pause running 9: External fault input 10: Up command 11: DOWN command 12: Clear UP/DOWN 13: Switch between A and B 14: Switch between A and A+B 15: Switch between B and A+B 16: Multi-step speed reference 1 17: Multi-step speed reference 2 18: Multi-step speed reference 3	7	⊙	71

List of Function Parameters

Function Code	Name	Description	Factory Setting	Modify	Serial No.
P5.04	S4 Terminal function	19: Multi-step speed reference 4 20: Multi-step speed pause 21: ACC/DEC time selection 1n time 22: ACC/DEC time selection 2 23: Reset simple PLC when stop 24: Pause simple PLC 25: Pause PID 26: Pause traverse operation 27: Reset traverse operation 28: Reset counter 29: Reset length 30: ACC/DEC ramp hold 31: Counter input 32: UP/DOWN invalid temporarily	0	⊗	72
P5.05	HDI terminal function	33-39: Reserved	0	⊗	73
P5.06	ON-OFF filter times	1~10	5	○	74
P5.07	FWD/REV control mode	0: 2-wire control mode 1 1: 2-wire control mode 2 2: 3-wire control mode 1 3: 3-wire control mode 2	0	⊗	75
P5.08	UP/DOWN setting change rate	0.01~50.00Hz/s	0.50Hz/s	○	76
P5.09	AI1 lower limit	0.00V~10.00V	0.00V	○	77
P5.10	AI1 lower limit corresponding setting	-100.0%~100.0%	0.0%	○	78
P5.11	AI1 upper limit	0.00V~10.00V	10.00V	○	79
P5.12	AI1 upper limit corresponding setting	-100.0%~100.0%	100.0%	○	80
P5.13	AI1 filter time constant	0.00s~10.00s	0.10s	○	81
P5.14	AI2 lower limit	0.00V~10.00V	0.00V	○	82
P5.15	AI2 lower limit corresponding setting	-100.0%~100.0%	0.0%	○	83

List of Function Parameters

Function Code	Name	Description	Factory Setting	Modify	Serial No.
P5.16	AI2 upper limit	0.00V~10.00V	10.00V	O	84
P5.17	AI2 upper limit corresponding setting	-100.0%~100.0%	100.0%	O	85
P5.18	AI2 input filter time	0.00s~10.00s	0.10s	O	86
P5.19	HDI function selection	0: Reference input 1: Length input 2: High-speed count input	0	O	87
P5.20	HDI lower limit	0.0 kHz ~50.0kHz	0.0KHz	O	88
P5.21	HDI lower limit corresponding setting	-100.0%~100.0%	0.0%	O	89
P5.22	HDI upper limit	0.0 KHz~50.0KHz	50.0KHz	O	90
P5.23	HDI upper limit corresponding setting	-100.0%~100.0%	100.0%	O	91
P5.24	HDI filter time constant	0.00s~10.00s	0.10s	O	92
P6 Group: Output Terminals					
P6.00	HDO selection	0: High-speed pulse output 1: ON-OFF output	0	O	93
P6.01	HDO ON-OFF output selection	0: No output 1: Running 2: Run forward 3: Run reverse 4: Fault output 5: FDT reached 6: Frequency reached 7: Zero speed running 8: Preset count value reached 9: Specified count value reached 10: Length reached 11: Simple PLC step completed 12: PLC cycle completed 13: Running time reached 14: Upper frequency limit reached 15: Lower frequency limit reached	1	O	94
P6.02	Relay 1 output selection	16: Ready 17: Auxiliary motor 1 started 18: Auxiliary motor 2 started 19-20: reserved	4	O	95
P6.03	Relay 2 output selection (4.0kW and above)		0	O	96

List of Function Parameters

Function Code	Name	Description	Factory Setting	Modify	Serial No.
P6.04	AO function selection	0: Running frequency 1: Reference frequency 2: Motor speed 3: Output current 4: Output voltage 5: Output power 6: Output torque 7: AI1 voltage 8: AI2 voltage/current 9: HDI frequency 10: Length value 11: Count value 12: reserved	0	○	97
P6.05	HDO function selection		0	○	98
P6.06	AO lower limit	0.0%~100.0%	0.0%	○	99
P6.07	AO lower limit corresponding output	0.00V ~10.00V	0.00V	○	100
P6.08	AO upper limit	0.0%~100.0%	100.0%	○	101
P6.09	AO upper limit corresponding output	0.00V ~10.00V	10.00V	○	102
P6.10	HDO lower limit	0.00%~100.00%	0.00%	○	103
P6.11	HDO lower limit corresponding output	0.000~ 50.000kHz	0.0kHz	○	104
P6.12	HDO upper limit	0.00%~100.00%	100.0%	○	105
P6.13	HDO upper limit corresponding output	0.0~ 50.0kHz	50.0kHz	○	106
P7 Group: Display Interface					
P7.00	User password	0~65535	0	○	107
P7.01	LCD language selection	Not available	0	○	108
P7.02	Parameter copy	Not available	0	⊗	109
P7.03	QUICK/JOG function selection	0: Jog 1: FDW/REV switching 2: Clear UP/DOWN setting 3: Quick debugging mode 1 4: Quick debugging mode 2 5: Quick debugging mode 3	0	○	110

Function Code	Name	Description	Factory Setting	Modify	Serial No.
P7.04	STOP/RST function selection	0: Valid when keypad control (P0.03=0) 1: Valid when keypad or terminal control (P0.03=0 or 1) 2: Valid when keypad or communication control (P0.03=0 or 2) 3: Always valid	0	O	111
P7.05	Keypad display selection	0: Preferential to external keypad 1: Both display, only external key valid. 2: Both display, only local key valid. 3: Both display and key valid.	0	O	112
P7.06	Running status display selection 1	0~0XFFFF BIT0: Output frequency BIT1: Reference frequency BIT2: DC bus voltage BIT3: Output voltage BIT4: Output current BIT5: Rotation speed BIT6: Line speed BIT7: Output power BIT8: Output torque BIT9: PID preset BIT10: PID feedback BIT11: Input terminal status BIT12: Output terminal status BIT13: Length value BIT14: Count value BIT15: Step No. of PLC or multi-step	0X07FF	O	113
P7.07	Running status display selection 2	0~0XFFFF BIT0: AI1 BIT1: AI2 BIT2: HDI frequency BIT3: Load percentage of motor BIT4: Load percentage of inverter BIT 5: Accumulated running time BIT6~15: Reserved	0X0000	O	114

List of Function Parameters

Function Code	Name	Description	Factory Setting	Modify	Serial No.
P7.08	Stop status display selection	0~0XFFFF BIT0: Reference frequency BIT1: DC bus voltage BIT2: Input terminal status BIT3: Output terminal status BIT4: PID preset BIT5: PID feedback BIT6: AI1 BIT7: AI2 BIT8: HDI frequency BIT9: Step No. of PLC or multi-step BIT10~15: Reserved	0x00FF	O	115
P7.09	Coefficient of rotation speed	0.1~999.9% Actual mechanical speed = 120 * output frequency * P7.09 / Number of poles of motor	100.0%	O	116
P7.10	Coefficient of line speed	0.1~999.9% Line speed = actual mechanical speed * P7.10	1.0%	O	117
P7.11	Rectify module temperature	0~100.0°C		•	118
P7.12	IGBT module temperature	0~100.0°C		•	119
P7.13	Software version			•	120
P7.14	Accumulated running time	0~65535h		•	121
P7.15	Third latest fault type	0: Not fault 1: IGBT Ph-U fault(OUT1) 2: IGBT Ph-V fault(OUT2) 3: IGBT Ph-W fault(OUT3)		•	122
P7.16	Second latest fault type	4: Over-current when acceleration(OC1) 5: Over-current when deceleration(OC2) 6: Over-current when constant speed running (OC3) 7: Over-voltage when acceleration(OV1) 8: Over-voltage when deceleration(OV2)		•	123

Function Code	Name	Description	Factory Setting	Modify	Serial No.
P7.17	Latest fault type	9: Over-voltage when constant speed running(OV3) 10: DC bus Under-voltage(UV) 11: Motor overload (OL1) 12: Inverter overload (OL2) 13: Input phase failure (SPI) 14: Output phase failure (SPO) 15: Rectify overheat (OH1) 16: IGBT overheat (OH2) 17: External fault (EF) 18: Communication fault (CE) 19: Current detection fault (ITE) 20: Autotuning fault (TE) 21: EEPROM fault (EEP) 22: PID feedback fault (PIDE) 23: Brake unit fault (BCE) 24: Reserved		•	124
P7.18	Output frequency at current fault			•	125
P7.19	Output current at current fault			•	126
P7.20	DC bus voltage at current fault			•	127
P7.21	Input terminal status at current fault			•	128
P7.22	Output terminal status at current fault			•	129
P8 Group: Enhanced Function					
P8.00	Acceleration time 1	0.1~3600.0s	Depend on model	O	130
P8.01	Deceleration time 1	0.1~3600.0s	Depend on model	O	131
P8.02	Acceleration time 2	0.1~3600.0s	Depend on model	O	132
P8.03	Deceleration time 2	0.1~3600.0s	Depend on model	O	133
P8.04	Acceleration time 3	0.1~3600.0s	Depend on model	O	134
P8.05	Deceleration time 3	0.1~3600.0s	Depend on model	O	135
P8.06	Traverse amplitude	0.0~100.0%	0.0%	O	136

List of Function Parameters

Function Code	Name	Description	Factory Setting	Modify	Serial No.
P8.07	Jitter frequency	0.0~50.0%	0.0%	O	137
P8.08	Rise time of traverse	0.1~3600.0s	5.0s	O	138
P8.09	Fall time of traverse	0.1~3600.0s	5.0s	O	139
P8.10	Auto reset times	0~3	0	O	140
P8.11	Reset interval	0.1~100.0s	1.0s	O	141
P8.12	Preset length	0~65535m	0m	O	142
P8.13	Actual length	0~65535m	0m	•	143
P8.14	Number of pulse per cycle	1~10000	1	O	144
P8.15	Perimeter of shaft	0.01~1000.00cm	10.00cm	O	145
P8.16	Ratio of length	0.001~10.000	1.000	O	146
P8.17	Coefficient of length correction	0.001~1.000	1.000	O	147
P8.18	Preset count value	P8.19~65535	0	O	148
P8.19	Specified count value	0~P8.18	0	O	149
P8.20	Preset running time	0~65535h	65535h	O	150
P8.21	FDT level	0.00~ P0.04	50.00Hz	O	151
P8.22	FDT lag	0.0~100.0%	5.0%	O	152
P8.23	Frequency arrive detecting range	0.0~100.0%(maximum frequency)	0.0%	O	153
P8.24	Droop control	0.00~10.00Hz	0.00Hz	O	154
P8.25	Auxiliary motor selection	0: Invalid 1: Motor 1 valid 2: Motor 2 valid 3: Both valid	0	O	155
P8.26	Auxiliary motor1 START/STOP delay time	0.0~3600.0s	5.0s	O	156
P8.27	Auxiliary motor2 START/STOP delay time	0.0~3600.0s	5.0s	O	157

List of Function Parameters

Function Code	Name	Description	Factory Setting	Modify	Serial No.
P8.28	Brake threshold voltage	115.0~140.0%	Depend on model	<input type="radio"/>	158
P8.29	Cooling fan control	0: Auto stop mode 1: Always working	0	<input type="radio"/>	159
P8.30	Restrain oscillation	0: Enabled 1: Disabled	1	<input type="radio"/>	160
P8.31	PWM mode	0: PWM mode 1 1: PWM mode 2 2: PWM mode 3	0	<input checked="" type="radio"/>	161
P9 Group: PID Control					
P9.00	PID preset source selection	0: Keypad 1: AI1 2: AI2 3: HDI 4: Multi-step 5: Communication	0	<input type="radio"/>	162
P9.01	Keypad PID preset	0.0%~100.0%	0.0%	<input type="radio"/>	163
P9.02	PID feedback source selection	0: AI1 1: AI2 2: AI1+AI2 3: HDI 4: Communication	0	<input type="radio"/>	164
P9.03	PID output characteristic	0: Positive 1: Negative	0	<input type="radio"/>	165
P9.04	Proportional gain (Kp)	0.00~100.00	0.10	<input type="radio"/>	166
P9.05	Integral time (Ti)	0.01~10.00s	0.10s	<input type="radio"/>	167
P9.06	Differential time (Td)	0.00~10.00s	0.00s	<input type="radio"/>	168
P9.07	Sampling cycle (T)	0.01~100.00s	0.10s	<input type="radio"/>	169
P9.08	Bias limit	0.0~100.0%	0.0%	<input type="radio"/>	170
P9.09	Feedback lost detecting value	0.0~100.0%	0.0%	<input type="radio"/>	171
P9.10	Feedback lost detecting time	0.0~3600.0s	1.0s	<input type="radio"/>	172

List of Function Parameters

Function Code	Name	Description	Factory Setting	Modify	Serial No.
PA Group: Simple PLC and Multi-step Speed Control					
PA.00	Simple PLC mode	0: Stop after one cycle 1: Hold last frequency after one cycle 2: Circular run	0	O	173
PA.01	Simple PLC status saving after power off	0: Disabled 1: Enabled	0	O	174
PA.02	Multi-step speed 0	-100.0~100.0%	0.0%	O	175
PA.03	0 th Step running time	0.0~6553.5s(h)	0.0s	O	176
PA.04	Multi-step speed 1	-100.0~100.0%	0.0%	O	177
PA.05	1 st Step running time	0.0~6553.5s(h)	0.0s	O	178
PA.06	Multi-step speed 2	-100.0~100.0%	0.0%	O	179
PA.07	2 nd Step running time	0.0~6553.5s(h)	0.0s	O	180
PA.08	Multi-step speed 3	-100.0~100.0%	0.0%	O	181
PA.09	3 rd Step running time	0.0~6553.5s(h)	0.0s	O	182
PA.10	Multi-step speed 4	-100.0~100.0%	0.0%	O	183
PA.11	4 th Step running time	0.0~6553.5s(h)	0.0s	O	184
PA.12	Multi-step speed 5	-100.0~100.0%	0.0%	O	185
PA.13	5 th Step running time	0.0~6553.5s(h)	0.0s	O	186
PA.14	Multi-step speed 6	-100.0~100.0%	0.0%	O	187
PA.15	6 th Step running time	0.0~6553.5s(h)	0.0s	O	188
PA.16	Multi-step speed 7	-100.0~100.0%	0.0%	O	189
PA.17	7 th Step running time	0.0~6553.5s(h)	0.0s	O	190
PA.18	Multi-step speed 8	-100.0~100.0%	0.0%	O	191
PA.19	8 th Step running time	0.0~6553.5s(h)	0.0s	O	192
PA.20	Multi-step speed 9	-100.0~100.0%	0.0%	O	193

Function Code	Name	Description	Factory Setting	Modify	Serial No.
PA.21	9 th Step running time	0.0~6553.5s(h)	0.0s	○	194
PA.22	Multi-step speed 10	-100.0~100.0%	0.0%	○	195
PA.23	10 th Step running time	0.0~6553.5s(h)	0.0s	○	196
PA.24	Multi-step speed 11	-100.0~100.0%	0.0%	○	197
PA.25	11 th Step running time	0.0~6553.5s(h)	0.0s	○	198
PA.26	Multi-step speed 12	-100.0~100.0%	0.0%	○	199
PA.27	12 th Step running time	0.0~6553.5s(h)	0.0s	○	200
PA.28	Multi-step speed 13	-100.0~100.0%	0.0%	○	201
PA.29	13 th Step running time	0.0~6553.5s(h)	0.0s	○	202
PA.30	Multi-step speed 14	-100.0~100.0%	0.0%	○	203
PA.31	14 th Step running time	0.0~6553.5s(h)	0.0s	○	204
PA.32	Multi-step speed 15	-100.0~100.0%	0.0%	○	205
PA.33	15 th Step running time	0.0~6553.5s(h)	0.0s	○	206
PA.34	ACC/DEC time selection for step 0~7	0~0XFFFF	0	○	207
PA.35	ACC/DEC time selection for step 8~15	0~0XFFFF	0	○	208
PA.36	Simple PLC restart selection	0: Restart from step 0 1: Continue from paused step	0	◎	209
PA.37	Time unit	0: Second 1: Minute	0	◎	210
PB Group: Protection Function					
PB.00	Input phase-failure protection	0: Disable 1: Enable	1	○	211

List of Function Parameters

Function Code	Name	Description	Factory Setting	Modify	Serial No.
PB.01	Output phase-failure protection	0: Disabled 1: Enabled	1	O	212
PB.02	Motor overload protection	0: Disabled 1: Normal motor 2: Variable frequency motor	2	⊙	213
PB.03	Motor overload protection current	20.0% ~ 120.0% (rated current of the motor)	100.0%	O	214
PB.04	Threshold of trip-free	70.0.0~110.0% (standard bus voltage)	80.0%	O	215
PB.05	Decrease rate of trip-free	0.00Hz~P0.04	0.00Hz	O	216
PB.06	Over-voltage stall protection	0: Disabled 1: Enabled	1	O	217
PB.07	Over-voltage stall protection point	110~150%	380V: 130% 220V: 120%	O	218
PB.08	Auto current limiting threshold	50~200%	G Model: 160% P Model: 120%	O	219
PB.09	Frequency decrease rate when current limiting	0.00~100.00Hz/s	10.00Hz/s	O	220
PB.10	Auto current limiting selection	0: Enabled 1: Disabled when constant speed	0	O	221
PC Group: Serial Communication					
PC.00	Local address	1~247, 0 stands for the broadcast address	1	O	222
PC.01	Baud rate selection	0: 1200BPS 1: 2400BPS 2: 4800BPS 3: 9600BPS 4: 19200BPS 5: 38400BPS	4	O	223

List of Function Parameters

Function Code	Name	Description	Factory Setting	Modify	Serial No.
PC.02	Data format	0: RTU, 1 start bit, 8 data bits, no parity check, 1 stop bit. 1: RTU, 1 start bit, 8 data bits, even parity check, 1 stop bit. 2: RTU, 1 start bit, 8 data bits, odd parity check, 1 stop bit. 3: RTU, 1 start bit, 8 data bits, no parity check, 2 stop bits. 4: RTU, 1 start bit, 8 data bits, even parity check, 2 stop bits. 5: RTU, 1 start bit, 8 data bits, odd parity check, 2 stop bits. 6: ASCII, 1 start bit, 7 data bits, no parity check, 1 stop bit. 7: ASCII, 1 start bit, 7 data bits, even parity check, 1 stop bit. 8: ASCII, 1 start bit, 7 data bits, odd parity check, 1 stop bit. 9: ASCII, 1 start bit, 7 data bits, no parity check, 2 stop bits. 10: ASCII, 1 start bit, 7 data bits, even parity check, 2 stop bits. 11: ASCII, 1 start bit, 7 data bits, odd parity check, 2 stop bits. 12: ASCII, 1 start bit, 8 data bits, no parity check, 1 stop bit. 13: ASCII, 1 start bit, 8 data bits, even parity check, 1 stop bit. 14: ASCII, 1 start bit, 8 data bits, odd parity check, 1 stop bit. 15: ASCII, 1 start bit, 8 data bits, no parity check, 2 stop bits. 16: ASCII, 1 start bit, 8 data bits, even parity check, 2 stop bits. 17: ASCII, 1 start bit, 8 data bits, odd parity check, 2 stop bits.	1	O	224
PC.03	Communication delay time	0~200ms	5ms	O	225
PC.04	Communication timeout delay	0.0: Disabled 0.1~100.0s	0.0s	O	226

List of Function Parameters

Function Code	Name	Description	Factory Setting	Modify	Serial No.
PC.05	Communication error action	0: Alarm and coast to stop 1: No alarm and continue to run 2: No alarm but stop according to P1.06 (if P0.03=2) 3: No alarm but stop according to P1.06	1	O	227
PC.06	Response action	Unit's place of LED 0: Response to writing 1: No response to writing Ten's place of LED 0: Reference not saved when power off 1: Reference saved when power off	0	O	228
PD Group: Supplementary Function					
PD.00	Low-frequency threshold of restraining oscillation	0~500	5	O	229
PD.01	High-frequency threshold of restraining oscillation	0~500	100	O	230
PD.02	Amplitude of restraining oscillation	0~10000	5000	O	231
PD.03	Boundary of restraining oscillation	0.0~P0.04	12.5Hz	O	232
PD.04	Over-modulation selection	0: Disabled 1: Enabled	0	O	233
PD.05	Reserved	0~1	0	•	234
PD.06	Reserved	0~1	0	•	235
PD.07	Reserved	0~1	0	•	236
PD.08	Reserved	0~1	0	•	237
PD.09	Reserved	0~1	0	•	238
PE Group: Factory Setting					
PE.00	Factory password	0~65535	*****	O	239

10. COMMUNICATION PROTOCOL

10.1 Interfaces

RS485: asynchronous, half-duplex.

Default: 8-E-1, 19200bps. See Group PC parameter settings.

10.2 Communication Modes

10.2.1 The protocol is Modbus protocol. Besides the common register Read/Write operation, it is supplemented with commands of parameters management.

10.2.2 The drive is a slave in the network. It communicates in 'point to point' master-slave mode. It will not respond to the command sent by the master via broadcast address.

10.2.3 In the case of multi-drive communication or long-distance transmission, connecting a 100~120Ω resistor in parallel with the master signal line will help to enhance the immunity to interference.

10.3 Protocol Format

Modbus protocol supports both RTU and ASCII mode. The frame format is illustrated as follows:

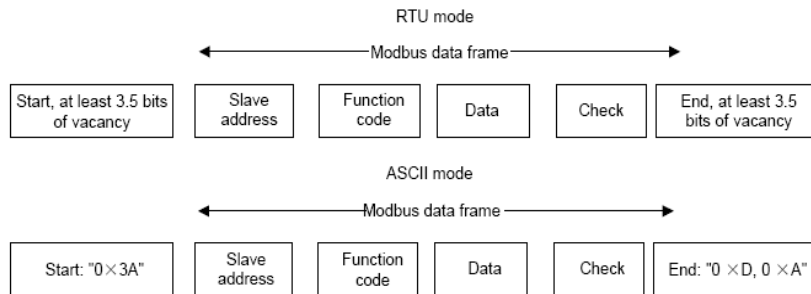

Modbus adopts "Big Endian" representation for data frame. This means that when a numerical quantity larger than a byte is transmitted, the most significant byte is sent first.

RTU mode

In RTU mode, the Modbus minimum idle time between frames should be no less than 3.5 bytes. The checksum adopts CRC-16 method. All data except checksum itself sent will be counted into the calculation. Please refer to section: CRC Check for more information.

Note that at least 3.5 bytes of Modbus idle time should be kept and the start and end idle time need not be summed up to it.

The table below shows the data frame of reading parameter 002 from slave node address 1.

Node addr.	Command	Data addr.		Read No.		CRC	
0x01	0x03	0x00	0x02	0x00	0x01	0x25	0xCA

The table below shows the reply frame from slave node address 1

Node addr.	Command	Bytes No.	Data		CRC	
0x01	0x03	0x02	0x00	0x00	0xB8	0x44

ASCII mode

In ASCII mode, the frame head is “0x3A”, and default frame tail is “0x0D” or “0x0A”. The frame tail can also be configured by users. Except frame head and tail, other bytes will be sent as two ASCII characters, first sending higher nibble and then lower nibble. The data have 7/8 bits. “A”~“F” corresponds to the ASCII code of respective capital letter. LRC check is used. LRC is calculated by adding all the successive bytes of the message except the head and tail, discarding any carriers, and then two’s complementing the result.

Example of Modbus data frame in ASCII mode:

The command frame of writing 0x0003 into address “0x1000” of slave node address 1 is shown in the table below:

LRC checksum = the complement of (01+06+10+00+0x00+0x03) = 0xE5

	Frame head	Node addr.		Command		Data addr.			
Code		0	1	0	6	1	0	0	0
ASCII	3A	30	31	30	36	31	30	30	30
Data to write				LRC		Frame tail			
0	0	0	3	E	5	CR		LF	
30	30	30	33	45	35	0D		0A	

10.4 Protocol function

Different respond delay can be set through drive’s parameters to adapt to different needs. For RTU mode, the respond delay should be no less than 3.5 bytes interval, and for ASCII mode, no less than 1ms.

The main function of Modbus is to read and write parameters. The Modbus protocol supports the following commands:

0x03	Read inverter’s function parameter and status parameters
0x06	Write single function parameter or command parameter to inverter

All drive’s function parameters, control and status parameters are mapped to Modbus R/W data address.

The data addresses of each function parameters please refer the sixth column of chapter 9.

The data address of control and status parameters please refer to the following table.

Parameter Description	Address	Meaning of value	R/W Feature
Control command	1000H	0001H: Forward	W/R
		0002H: Reverse	
		0003H: JOG forward	
		0004H: JOG reverse	
		0005H: Stop	
		0006H: Coast to stop	
		0007H: Reset fault	
		0008H: JOG stop	
Inverter status	1001H	0001H: Forward running	R
		0002H: Reverse running	
		0003H: Standby	
		0004H: Fault	
Communication setting	2000H	Communication Setting Range (-10000~10000) Note: the communication setting is the percentage of the relative value (-100.00%~100.00%). If it is set as frequency source, the value is the percentage of the maximum frequency (P0.04). If it is set as PID (preset value or feedback value), the value is the percentage of the PID.	W/R
Status parameters	3000H	Output frequency	R
	3001H	Reference frequency	R
	3002H	DC Bus voltage	R
	3003H	Output voltage	R
	3004H	Output current	R
	3005H	Rotation speed	R
	3006H	Output power	R
	3007H	Output torque	R
	3008H	PID preset value	R
	3009H	PID feedback value	R
	300AH	Input terminal status	R
	300BH	Output terminal status.	R
	300CH	Input of AI1	R
	300DH	Input of AI2	R
	300EH	Reserved	R
	300FH	Reserved	R
3010H	HDI frequency	R	
3011H	Reserved	R	
3012H	Step No. of PLC or multi-step	R	

	3013H	Length value	R
	3014H	External counter input	R
	3015H	Reserved	R
	3016H	Device code	R
Fault info address	5000H	This address stores the fault type of inverter. The meaning of each value is same as P7.15.	R
ModBus communication fault info address	5001H	0000H: No fault 0001H: Wrong password 0002H: Command code error 0003H: CRC error 0004H: Invalid address 0005H: Invalid data 0006H: Parameter change invalid 0007H: System locked 0008H: Busy (EEPROM is storing)	R

The above shows the format of the frame. Now we will introduce the Modbus command and data structure in details, which is called protocol data unit for simplicity. Also MSB stands for the most significant byte and LSB stands for the least significant byte for the same reason. The description below is data format in RTU mode. The length of data unit in ASCII mode should be doubled.

Protocol data unit format of reading parameters:

Request format:

Protocol data unit	Data length(bytes)	Range
Command	1	0x03
Data Address	2	0~0xFFFF
Read number	2	0x0001~0x0010

Reply format (success):

Protocol data unit	Data length(bytes)	Range
Command	1	0x03
Returned byte number	2	2* Read number
Content	2* Read number	

If the command is reading the type of inverter (data address 0x3016), the content value in reply message is the device code:

The high 8 bit of device code is the type of the inverter, and the low 8 bit of device code is the sub type of inverter.

For details, please refer to the following table:

High byte	Meaning	Low byte	Meaning
00	CHV	01	Universal type
		02	For water supply
		03	Middle frequency 1500HZ
		04	Middle frequency 3000HZ
01	CHE	01	Universal type
		02	Middle frequency 1500HZ
02	CHF	01	Universal type

If the operation fails, the inverter will reply a message formed by failure command and error code. The failure command is (Command+0x80). The error code indicates the reason of the error; see the table below.

Value	Name	Mean
01H	Illegal command	The command from master can not be executed. The reason maybe: 1. This command is only for new version and this version can not realize. 2. Slave is in fault status and can not execute it.
02H	Illegal data address.	Some of the operation addresses are invalid or not allowed to access.
03H	Illegal value	When there are invalid data in the message framed received by slave. Note: This error code does not indicate the data value to write exceed the range, but indicate the message frame is a illegal frame.
06H	Slave busy	Inverter is busy(EEPROM is storing)
10H	Password error	The password written to the password check address is not same as the password set by P7.00.
11H	Check error	The CRC (RTU mode) or LRC (ASCII mode) check not passed.
12H	Written not allowed.	It only happen in write command, the reason maybe: 1. the data to write exceed the range of according parameter 2. The parameter should not be modified now. 3. The terminal has already been used.
13H	System locked	When password protection take effect and user does not unlock it, write/read the function parameter will return this error.

Protocol data unit format of writing single parameter:

Request format:

Protocol data unit	Data length(bytes)	Range
Command	1	0x06
Data Address	2	0~0xFFFF
Write Content	2	0~0xFFFF

Reply format (success):

Protocol data unit	Data length(bytes)	Range
Command	1	0x06
Data Address	2	0~0xFFFF
Write Content	2	0~0xFFFF

If the operation fails, the inverter will reply a message formed by failure command and error code. The failure command is (Command+0x80). The error code indicates the reason of the error; see table 1.

10.5 Note:

10.5.1 Between frames, the span should not less than 3.5 bytes interval, otherwise, the message will be discarded.

10.5.2 Be cautious to modify the parameters of PC group through communication, otherwise may cause the communication interrupted.

10.5.3 In the same frame, if the span between two .near bytes more than 1.5 bytes interval, the behind bytes will be assumed as the start of next message so that communication will failure.

10.6 CRC Check

For higher speed, CRC-16 uses tables. The following are C language source code for CRC-16.

```

unsigned int crc_cal_value(unsigned char *data_value,unsigned char data_length)
{
    int i;
    unsigned int crc_value=0xffff;
    while(data_length--)
    {
        crc_value^=*data_value++;
        for(i=0;i<8;i++)
        {
            if(crc_value&0x0001)crc_value=(crc_value>>1)^0xa001;
            else crc_value=crc_value>>1;
        }
    }
    return(crc_value);
}

```

10.7 Example

10.7.1 RTU mode, read 2 data from 0004H

The request command is:

START	T1-T2-T3-T4 (transmission time of 3.5 bytes)
Node address	01H
Command	03H
High byte of start address	00H
Low byte of start address	04H
High byte of data number	00H
Low byte of data number	02H
Low byte of CRC	85H
High byte of CRC	CAH
END	T1-T2-T3-T4 (transmission time of 3.5 bytes)

The reply is :

START	T1-T2-T3-T4 (transmission time of 3.5 bytes)
Node address	01H
Command	03H
Returned byte number	04H
Higher byte of 0004H	00H
Low byte of 0004H	00H
High byte of 0005H	00H
Low byte of 0005H	00H
Low byte of CRC	43H
High byte of CRC	07H
END	T1-T2-T3-T4 (transmission time of 3.5 bytes)

10.7.2 ASCII mode, read 2 data from 0004H:

The request command is:

START	⋮
Node address	'0'
	'1'
Command	'0'
	'3'
High byte of start address	'0'
	'0'
Low byte of start address	'0'
	'4'
High byte of data number	'0'
	'0'
Low byte of data number	'0'
	'2'
LRC CHK Hi	'F'
LRC CHK Lo	'6'
END Lo	CR
END Hi	LF

The reply is

START	⋮
Node address	'0'
	'1'
Command	'0'
	'3'
Returned byte number	'0'
	'4'
Higher byte of 0004H	'0'
	'0'
Low byte of 0004H	'0'
	'0'
High byte of 0005H	'0'
	'0'
Low byte of 0005H	'0'
	'0'
LRC CHK Lo	'F'
LRC CHK Hi	'8'
END Lo	CR
END Hi	LF

10.7.3 RTU mode, write 5000(1388H) into address 0008H, slave node address 02.

The request command is:

START	T1-T2-T3-T4 (transmission time of 3.5 bytes)
Node address	02H
Command	06H
High byte of data address	00H
Low byte of data address	08H
High byte of write content	13H
Low byte of write content	88H
Low byte of CRC	05H
High byte of CRC	6DH
END	T1-T2-T3-T4 (transmission time of 3.5 bytes)

The reply command is:

START	T1-T2-T3-T4 (transmission time of 3.5 bytes)
Node address	02H
Command	06H
High byte of data address	00H
Low byte of data address	08H
High byte of write content	13H
Low byte of write content	88H
Low byte of CRC	05H
High byte of CRC	6DH
END	T1-T2-T3-T4 (transmission time of 3.5 bytes)

10.7.4 ASCII mode, write 5000(1388H) into address 0008H, slave node address 02.

The request command is:

START	':'
Node address	'0'
	'2'
Command	'0'
	'6'
High byte of data address	'0'
	'0'
Low byte of data address	'0'
	'8'
High byte of write content	'1'
	'3'
Low byte of write content	'8'
	'8'
LRC CHK Hi	'5'
LRC CHK Lo	'5'
END Lo	CR
END Hi	LF

The reply command is:

START	':'
Node address	'0'
	'2'
Command	'0'
	'6'
High byte of data address	'0'
	'0'
Low byte of data address	'0'
	'8'
High byte of write content	'1'
	'3'
Low byte of write content	'8'
	'8'
LRC CHK Hi	'5'
LRC CHK Lo	'5'
END Lo	CR
END Hi	LF